



Read Me First

When installing the A2000 GForce040, the 9-pin serial port at the rear of the GForce040 may become stuck on the metal chassis of the A2000. Removing the plastic CPU Slot Guide in the front the A2000 will give enough clearance to insert the GForce040 properly.

If removing the Slot Guide does not provide enough clearance, loosen the upper right screw (looking from the rear of the machine) holding the power supply to the chassis. This should allow more than enough room to insert the GForce040.

A program called '*SetDevice*' was not documented in the manual. A description of its function can be found in the *ReadMe* file on the installation floppy, located in the *GVP* drawer. It is recommended that you run this program in the s:user-startup file, so that it is running everytime you turn on the machine — The normal installation procedure automatically inserts this command for you.

If you have a Fan/HeatSink assembly that connects directly to the A2000 GForce040 board (using a 3-pin connector), ignore the instructions on pages 26 & 27 for connecting the fan to the A2000 power supply directly.



FCC STATEMENT

WARNING: This equipment has been designed to comply with the limits for a Class B computing device, pursuant to Part 15 of the Federal Communications Commission's rules. These rules and regulations are designed to provide reasonable protection against radio and television interference in a residential installation. If not installed properly, in strict accordance with the manufacturer's instructions, it may cause interference. If you suspect interference, you can test this equipment by turning it on and off. If you still experience interference with the equipment switched off, then the cause lies elsewhere. If this equipment does cause interference when switched on, any or all of the following suggestions may correct the problem.

- Reorient the antenna or plug on the radio or television receiver
- Change the relative positions of the GVP equipment and the radio or television receiver
- Plug the GVP equipment into a different outlet so that the peripheral and radio or television receiver are on different circuits.

CAUTION: Only equipment with shield-grounded cables (computer input-output devices, terminals, printers, etc.), certified to comply with Class B limits, can be attached to this device. Operation with non-certified equipment may result in communications interference.

Your house AC wall receptacle must be a three-pronged type (AC grounded). If not, contact an electrician to install the proper receptacle. If a multi-receptacle switch box or "power strip" is used to connect the computer and GVP peripherals to AC, then all receptacles must share a common ground.

If necessary, contact your dealer or an experienced radio-TV technician for additional suggestions. You may find the following FCC booklet helpful: "How to Identify and Resolve Radio-TV Interference Problems." The booklet is available from the U.S. Government Printing Office, Washington, D.C. 20402, stock no. 004-000-00345-4.

USER'S GUIDE

A2000
G-FORCE™
040 COMBO

A 68040-BASED ACCELERATOR FOR THE AMIGA® 2000





A2000
G-Force '040

33 MHz 68040

Accelerator

for the

Amiga 2000



This manual, the A2000 G-Force '040 accelerator, distribution disk and all related materials are copyright 1992, Great Valley Products, Inc. (GVP). All rights reserved.

This product requires version 2.04, or later, of Kickstart. The user is responsible to secure and have this installed. Installation of this product requires some degree of mechanical ability and precautions against electrostatic discharge. The user assumes all risks when this installation is performed by anyone other than a certified GVP dealer.

Workbench, Kickstart, Amiga, A2000, A2500, AmigaDOS and Enhancer are all registered trademarks of Commodore International, Ltd. 68000, 68030, 68040, 68881 and 68882 are trademarks of Motorola, Inc. All other product trade names and designations are used for illustrative purposes only and are in no way endorsements of those products or infringements on the copyrighted properties of their manufacturers.



TABLE OF CONTENTS

1. Introduction.....	1
2. Getting Started.....	3
3. Configuration.....	6
Jumpers.....	7
Memory.....	11
Adding RAM.....	13
Port options.....	17
4. Hardware Installation.....	22
5. Power Up Test.....	28
6. Software Installation.....	29
Install040.....	30
7. Softwar Reference.....	32
FastPrep 2.0.....	32
GVPCpuCtrl.....	32
GVPScsiCtrl.....	34
GVP Extended Input/Output Ports.....	37
GVPIOControl.....	38
GVPSerial.....	41
CPU.....	46
GVPIInfo.....	47
8. Theory of Operation.....	49



Appendix A. Hard Drive Installation.....	55
SCSI Pin Assignments.....	63
Appendix B. Technical Support.....	64
Appendix C. Problem Reporting Form.....	65
Index.....	68



CHAPTER I.

INTRODUCTION

Congratulations on your purchase of the GVP A2000 G-Force '040 accelerator. This product represents the most powerful performance upgrade available for any Amiga, anywhere. The A2000 G-Force '040 board plugs into the Processor Direct slot of any model A2000 Amiga equipped with version 2.04, or later, Kickstart in ROM. A2000 owners with older versions of the operating system will need to obtain the 2.04 ROM from their Commodore dealer.

GVP has engineered the A2000 G-Force '040 to provide 100% backward compatibility with the original A2000. An accompanying utility program: GVPCpuCtrl provides the means to select the A2000's original 68000 processor as the main CPU. This feature ensures that any software that will not run on a 68040 processor can still be used.

Product Identification

The A2000 G-Force '040 employs the most advanced state-of-the-art technologies of any product in the Amiga market. Among its features are:

- Motorola MC68040 CPU running at 33 MHz
 - Integrated Floating Point arithmetic Unit
 - 4 Kilobyte instruction cache
 - 4 Kilobyte data cache

- 22 Million instructions per second (*MIPS*)

- 3.75 Million floating point operations per second (*MFLOPS*)



- Support for 4 or 16 Megabyte SIMM modules provides a maximum of 16 or 64 Megabytes of onboard 32-bit wide FAST RAM
- Full support for 68040 Burst mode (*with 16 or 64 MB memory configurations*)
- GVP's high-performance autobooting DMA SCSI controller
- GVP's FaaastROM and FaaastPrep SCSI software technology
- GVP's custom designed Very Large Scale Integration (VLSI) DMA Peripheral and RAM Controller chip (DPRC) for lowest possible component count
- One additional Amiga or IBM compatible parallel port and one additional RS 232 compatible serial port
- Special hardware allows system ROM to be copied into high-speed on-board RAM for maximum performance
- Software switchable fallback mode supports the A2000's original 68000 for full backward compatibility
- Surface Mount Technology for more reliable assembly and reduced cost to the user
- 8-layer Printed Circuit Board for maximum system integration

In addition, an optional mounting bracket allows you to *piggyback* a low-profile 3.5" SCSI hard drive onto the back of the A2000 G-Force '040 board, providing a complete workstation quality subsystem in less space than some SCSI-only hard cards. The A2000 G-Force '040 accelerator mounts in the Amiga 2000's CPU direct slot, leaving all the standard Zorro expansion slots free for other uses.



NOTE: If an external SCSI connection port is required, you will need to replace one of your existing Zorro slot covers—or the second CPU slot cover—with the supplied connector bracket (as described in Chapter 3 – Configuration).

CHAPTER 2.

GETTING STARTED

This chapter provides an overview of the remainder of this document. Although we have attempted to present all relevant information in a complete and systematic fashion, each individual user may need to reference particular discussions out of sequence. This manual is organized as follows:

- Chapter 1. Introduction
- Chapter 2. Getting Started
- Chapter 3. Configuration
- Chapter 4. Hardware Installation
- Chapter 5. Power-Up Test
- Chapter 6. Software Installation
- Chapter 7. Software Reference
- Chapter 8. Theory of Operation
- Appendix A. Hard Drive Installation
- Appendix B. Technical Support
- Appendix C. Problem Reporting Form
- Index

Listed below is a typical step-by-step procedure for getting your new A2000 G-Force '040 accelerator up and running in the shortest amount of time.

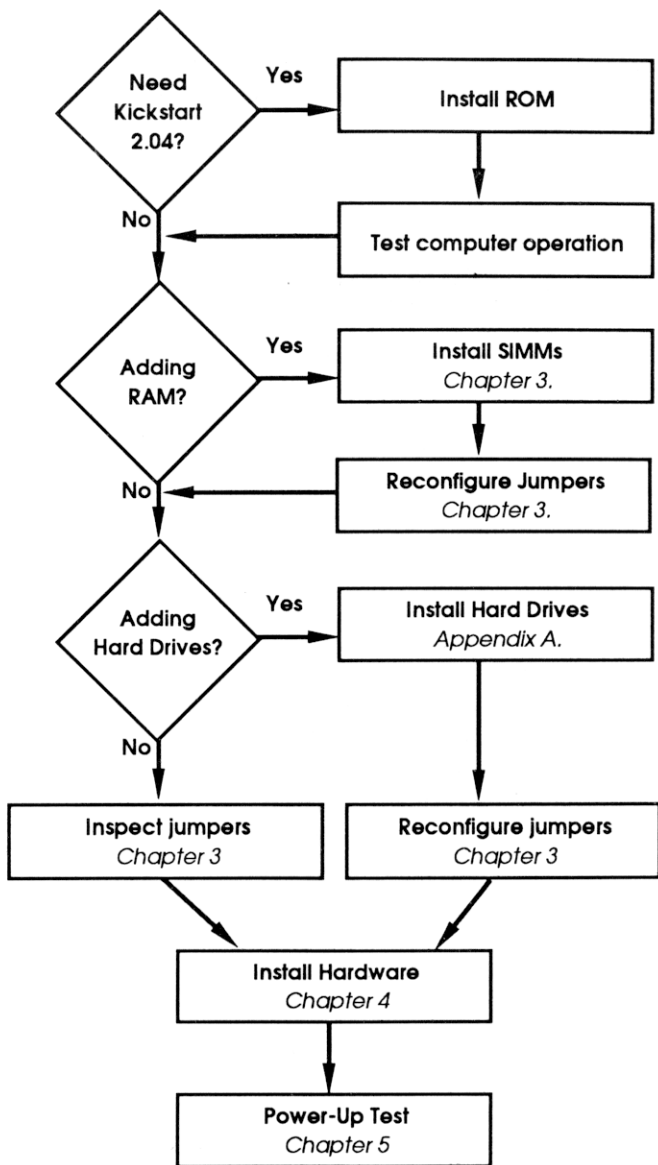

Figure 2.1 – Getting Started flow chart.



- 1) **Install Kickstart ROM** – If your A2000 does not have Kickstart version 2.04, or later, in ROM, you must install it before proceeding.
 - 1a) **Test new ROM installation** – If you have installed the 2.04 ROM chip into your system, power-up and ensure that everything works correctly before proceeding.
- 2) **Inspect board for configuration** – If you are installing the G-Force board as received (*i.e.*: *not adding RAM*), check the board's jumper settings against the factory defaults as described in *Tables 3.1–3.3* in *Chapter 3*.
 - 2a) **Add RAM and reconfigure** – If you plan to install additional RAM, follow the procedure as described in *Chapter 3*. Be sure to reset the appropriate jumpers according to *Table 3.1*.
 - 2b) **Add Hard Drives and reconfigure** – If you plan to run one or more hard drives using the A2000 G-Force '040's built-in SCSI controller, choose from the procedures described in *Appendix A*. Various methods of mounting hard drives are discussed. Be sure to reset the appropriate jumpers according to *Table 3.1*.
- 3) **Install Hardware** – Once properly configured, the A2000 G-Force '040 board can be installed into the Amiga's Processor slot. This procedure is described in *Chapter 4*.
- 4) **Run Power-Up Test** – Determine that your G-Force '040 accelerated system functions correctly (*Chapter 5*).

When you have completed steps 1–4, you are done. We recommend you read all of *Chapter 7 – Using Software*, in order to fully understand the software options available to you on the A2000 G-Force '040. Refer to this chapter, as needed, to best match your computing environment to the work at hand.



CHAPTER 3.

CONFIGURATION

Configuration Options

The A2000 G-Force '040 accelerator is normally shipped with 4 MB of 32-bit memory installed. It is expandable to 16 MB, using 4 MB SIMMs; or to 64 MB, using 16 MB SIMMs. The procedure for adding memory is detailed below.

The G-Force '040 also includes its own parallel port which can be set as an Amiga standard or IBM standard port. A procedure for making this selection is also discussed in this chapter.

The additional serial and parallel ports provided by the A2000 G-Force '040 board are mounted at the rear of the board and extend through the opening at the back of the Amiga 2000's processor slot. Provision is made for an additional 25-pin external SCSI connector, which mounts in one of the other available slot cover locations. The procedure for installing this additional port is also described below.

Even if you are not making configuration changes to the A2000 G-Force '040 board, we recommend that you check the board's jumper positions, as received, against the Factory Default configuration settings presented in Tables 3.1–3.3. These jumpers may have become dislodged during shipping.

CAUTION: G-Force '040 accelerator boards use CMOS technology electronic components. They are extremely sensitive to static discharge or physical shock. Always be sure to ground yourself by touching a metal surface prior to handling the board or its components. Do not drop or physically jar the board or its components. Failure to observe these precautions may result in irreparable damage to the G-Force board.

“What you need”

In most cases, no tools are required to configure a G-Force '040 board. It is always a good idea, when handling electronic components, to use a suitably grounded anti-static wrist strap. If you do not use an anti-static strap, make sure to touch some grounded metal surface prior to handling RAM SIMMs or other parts.

Jumpers

All user configurable settings on the G-Force '040 board are accomplished through the use of *jumper pins* and *shorting blocks*. Scattered around the board are a number of upright metal pins. These are connection points for various open circuits on the board. To configure certain options, you can install a shorting block onto a pair of pins, completing the circuit.

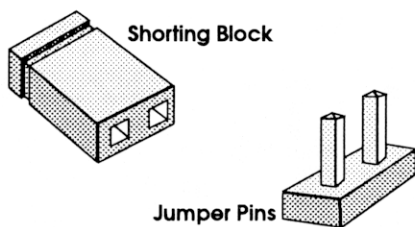

Figure 3.1 – Jumper block and pins.

NOTE: All jumpers have polarity which is indicated either by a pointed end on the jumper pin mount, itself, or in white ink on the surface of the circuit board. On both two and three pin jumpers, pin one is the pin closest to the pointed end.

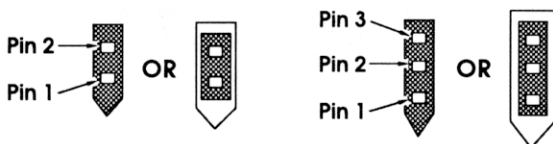

Figure 3.2 – Jumper pin numbering.

CAUTION: This diagram shows all available jumper and pin locations. Many of the pins on the A2000 G-Force '040 board are reserved by GVP. Never indiscriminately apply jumper blocks to any set of pins on the G-Force board. GVP will not be responsible to repair boards damaged as a result of tampering with reserved jumper settings.

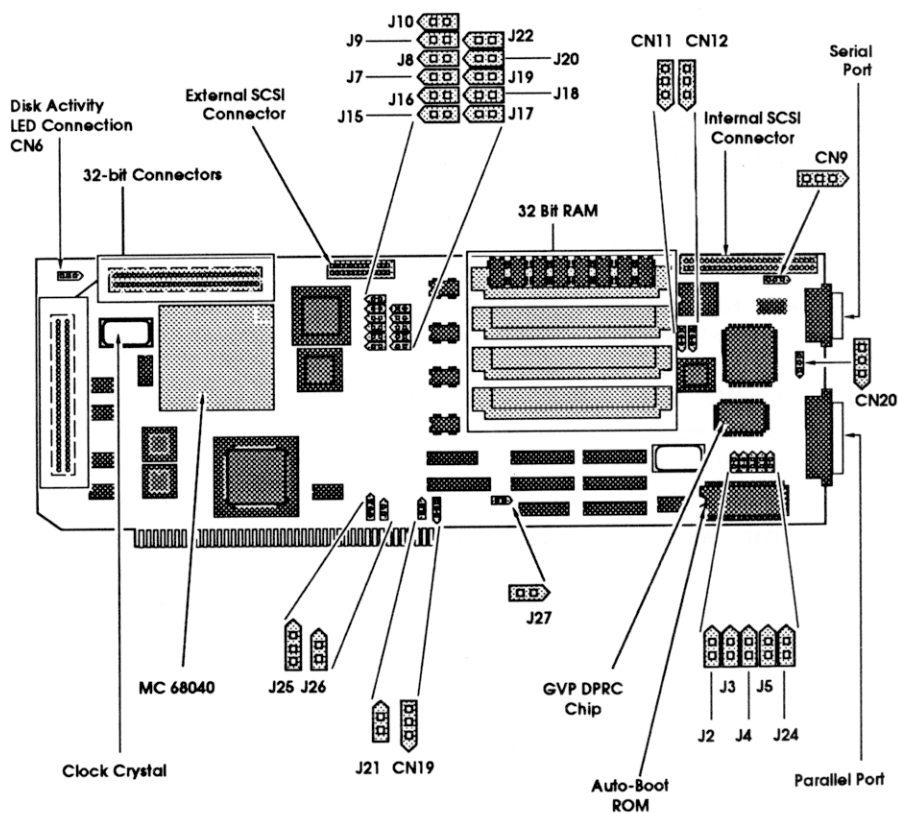

Figure 3.3 – A2000 G-Force '040 board showing jumper locations.

**Table 3.1 – A2000 G-Force '040
User Jumper Assignments.**

Jumper	Open Position	Closed Position	Factory Default
J4	SCSI Drive Connected	SCSI Drive Disconnected	Open or Closed*
J5	Boot ROM Disabled	Boot ROM Enabled	Closed
J7	68040 MMU Enabled	68040 MMU Disabled	Open
J20	16 MB SIMMs used	4 MB SIMMs used	Closed
J22	Burst Mode Enabled**	Burst Mode Disabled	Open
J26	No DTAK pullup***	DTAK pullup enabled	Open
Jumper	Pins 1 & 2	Pins 2 & 3	
CN9	Amiga Std. Parallel Port	IBM Std. Parallel Port	Pins 2 & 3 shorted
CN6	Connect SCSI hard disk drive read/write indicator LED.		

* – Depending on your purchased configuration.

** – 68040 Burst mode requires that all four SIMM sockets be populated with either 4 MB or 16 MB SIMMs.

*** – The DTAK pullup resistor corrects a flaw in old version A2000s. If your Amiga A2000 motherboard is Rev. 4.3 or earlier, J26 should be closed.

CAUTION: Be sure to short only the two pins on a single jumper block. Serious damage could result from shorting pins from two adjacent jumpers.

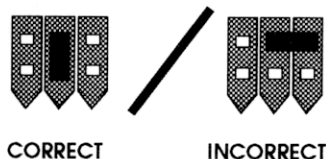

Figure 3.4 – Correct and incorrect jumper installation.

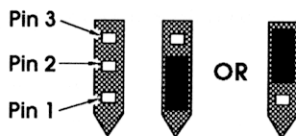

Figure 3.5 – Correct 3-pin jumper installations.



**Table 3.2 – A2000 G-Force '040
Factory Jumper Assignments.**

Jumper	Open Position	Closed Position	Factory Default
J2	RESERVED	RESERVED	Open
J3	RESERVED	RESERVED	Open
J8	RESERVED	RESERVED	Closed
J9	RESERVED	RESERVED	Open
J10	RESERVED	RESERVED	Closed
J15	RESERVED	RESERVED	Open
J16	RESERVED	RESERVED	Closed
J17	RESERVED	RESERVED	Open
J18	RESERVED	RESERVED	Open
J19	RESERVED	RESERVED	Open
J21	RESERVED	RESERVED	Closed
J24	RESERVED	RESERVED	Closed
J27	RESERVED	RESERVED	Closed

Table 3.1 shows those jumper settings alterable by the user. Tables 3.2 and 3.3 show just the factory default settings for jumpers reserved by GVP. Dealers and developers who need a more complete description of the functions controlled by these reserved settings should call GVP for further details.

Except for memory configuration, 68040 Burst, MMU, Cache, and SCSI hard drive options, the factory settings should not be altered.



Table 3.2 – A2000 G-Force '040
Three-pin Jumper Assignments.

Jumper	Pins 1 & 2	Pins 2 & 3	
CN11	RESERVED	RESERVED	Pins 2 & 3 shorted
CN12	RESERVED	RESERVED	Pins 1 & 2 shorted
CN19	RESERVED	RESERVED	No pins shorted
CN20	RESERVED	RESERVED	Pins 1 & 2 shorted
J25	RESERVED	RESERVED	NO PINS SHORTED!

- * – Jumper J25 carries 12 volts DC and is reserved for future use. UNDER NO CIRCUMSTANCES SHOULD THESE PINS BE SHORTED!

Memory

The A2000 G-Force '040 has memory resources allocated in four Banks on the top, central portion of the board. This arrangement uses *Single Inline Memory Modules (SIMMs)* in easy to use snap-in sockets. The Banks are numbered in series from top to bottom (see *Figure 3.6*). A2000 G-Force '040 boards ship with one four-Megabyte SIMM installed, and can be upgraded in increments of 4 Megabytes, to a maximum of 16 MB.

An alternate memory configuration allows the use of 16-Megabyte SIMMs for a maximum of 64 Megabytes of RAM. You may not mix 4 and 16 Megabyte SIMMs, however, so it is necessary to remove any 4 Megabyte SIMMs before you can install a 16 Megabyte SIMM.

All memory mounted on a A2000 G-Force '040 board is configured as “Extended” RAM. This provides for maximum system expansion while maintaining complete compatibility with other existing Auto-config memory peripherals — refer to *Chapter 8 – Theory of Operation* for more information about Extended memory.

32-bit memory

Whatever amount of memory is installed in your system, and no matter how it is configured, the A2000 G-Force '040 board will always attempt to use 32-bit FAST RAM before any other kind. Only after its store of 32-bit memory has been consumed, will the system use 16-bit memory. In this way, the G-Force board makes most efficient use of its resources for the maximum attainable performance.

Users should be aware, however, of the possibility that some applications may not work with Extended RAM on the A2000G-Force '040 board. These applications will generally also not work on an Amiga A3000, either. Such programs are not "32-bit pure;" their authors made some assumptions about the addressing range of the target computer and used the high-order address bits in unauthorized ways. The most surprising "32-bit impure" program is AmigaBASIC.

Some programs, while they cannot access or use memory beyond the Auto-config range, will operate happily by ignoring Extended memory. Such programs will work fine on a G-Force '040 equipped system.

Still other programs may be able to cope with Extended RAM, but may not run correctly on the 68040 processor. The solution for such software requires rebooting your system under 68000 control. Refer to *Chapter 7 – Software Reference* for details on the use of GVP-CpuCtrl.

As Workbench 2.0 and the current crop of programmers' tools become more widespread, we expect to find fewer compatibility problems with Amiga software. In the meantime, however, you should ask your dealer whether a particular program is '040 compatible before deciding to purchase it. While there is no way to fix "broken" software, a general rule of thumb applies when selecting software for use on your system:

If a program runs correctly on an Amiga A3000, it will also work with the A2000 G-Force '040 board.

Adding RAM

There are four RAM SIMM sockets on the A2000 G-Force '040; located in the rear third, at the top of the board (*see Figure 3.3*). In all cases, there should already be one SIMM installed in the topmost socket.

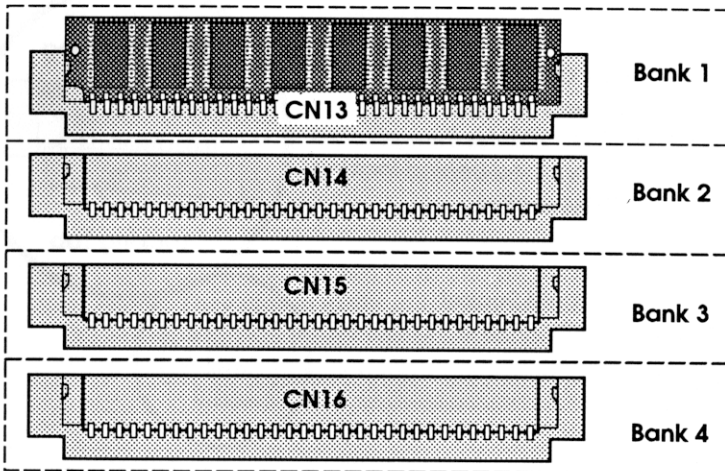

Figure 3.6 – A2000 G-Force '040 board RAM Bank arrangement.

The A2000 G-Force '040 board will automatically sense whether a SIMM is installed in each socket and will configure itself accordingly. If all four sockets are filled, jumper J22 can be closed (*shorted*), allowing the 68040 to operate in Burst mode.

The SIMM package is a convenient, cost-effective, relatively rugged component with a high degree of reliability. They are much easier to install than most single-chip arrangements. A *GVP SIMM-32* consists of eight tiny memory chips mounted on a single small printed circuit board. All of the connection points for the memory chips are arrayed along one edge of the SIMM and mate with the contacts of a matching SIMM socket on the G-Force board. These SIMM sockets can be populated one at a time, as finances permit, or all at once.

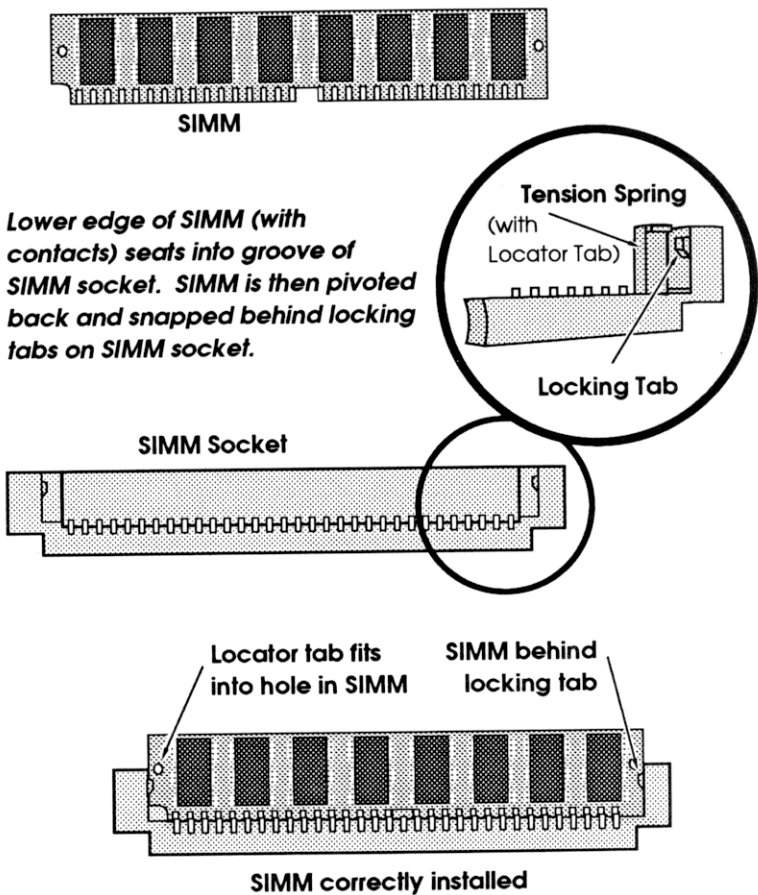
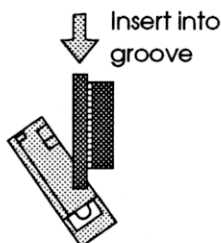

Figure 3.7 – SIMMs, Sockets and installation.

Installation procedure:

- 1) If you are not using an anti-static wrist strap, be sure to ground yourself before touching the G-Force '040 board or any of its components.
- 2) Lay the G-Force '040 board on the anti-static envelope it came packaged in.
- 3) Note the location of the SIMM sockets in the upper right-hand quadrant of the G-Force board. The sockets are numbered from top to bottom in ascending order. The sockets must be used in order from top to bottom.
- 4) The SIMMs are designed to fit into the sockets one way only. They slide in easily and, when rotated toward the board, snap into place. Figure 3.7 shows the SIMM and Socket in detail.

Orient the first SIMM such that the memory chips are facing you and the edge with the silver contacts is pointing down. These contacts will mate with the corresponding connectors inside the socket.



Step 4.
(Side View)

Rotate back
toward board

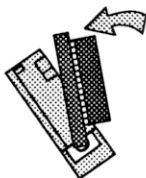

Step 5a.
(Side View)

- 5) With the SIMM correctly seated, rotate it toward the board.

The SIMM will move only a few degrees before the retaining tabs snap into place.

SIMM snaps
into place.

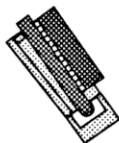

Step 5b.
(Side View)

These tabs secure the SIMM into position and ensure proper contact between the SIMM and socket connectors.

- 6) Repeat this procedure for any other SIMMs you wish to install at this time. Be sure to correctly set jumper J20 to correctly reflect the size of the SIMM installed (*4 or 16 MB*).

Port Options

The A2000 G-Force '040 board offers several additional input/output ports: A high-speed serial port capable of transfers up to 625,000 bits per second uses the 9-pin DB-style connector mounted at the top, back edge of the card. The DB-25 connector below this is an additional parallel port that can be user set to either Amiga or IBM standard pin configuration.

Support for an external SCSI bus is also provided in the form of a 26-pin header connector at the top edge of the G-Force board. This can be connected using the supplied ribbon cable and replacement slot cover as described below.

Parallel Port

The Amiga's standard parallel port differs slightly from the parallel port on most MS/DOS computers. This can lead to problems when cabling various types of printers. The Amiga parallel port also supplies voltage on one of its pins (*allowing such devices as sound samplers and video digitizers to derive their power from the Amiga's supply*). If you mistakenly connect the wrong type of printer cable, this voltage can damage printers or other parallel devices that do not expect to find voltage on this pin.

The G-Force '040 board's parallel port can be set to behave as either an Amiga parallel port (*with 5 volts supplied on pin 14*), or as an IBM standard parallel port (*compatible with most off the shelf printer cables and devices*). Selection is accomplished by setting jumper CN9 as shown:

WARNING: When configured as an Amiga standard parallel port, pin 14 on the DB-25 connector will carry 5 volts. Be sure to use proper cabling in order to avoid damaging your parallel peripherals.



Figure 3.8 – Jumper setting for G-Force '040 parallel port.

External SCSI Port

The A2000 G-Force '040 board uses a high-performance SCSI II controller for interfacing hard drives and other data input or output equipment. This manual discusses setting up a SCSI hard drive, but many other types of devices can also communicate across the SCSI data bus.

SCSI stands for *Small Computer Standard Interface* and is the general term for an industry-wide specification governing how certain devices should be connected to one another. The SCSI standard specifies a 50-wire data bus that can connect up to a maximum of 8 individual devices. The G-Force board's SCSI controller, itself, is always counted as one of these 8 and has the designator ID #7.

The 50-pin internal bus connector is the rearmost component on the G-Force card. The 26-pin external bus connector is located approximately mid-way down the length of the card, just before the RAM SIMM modules.

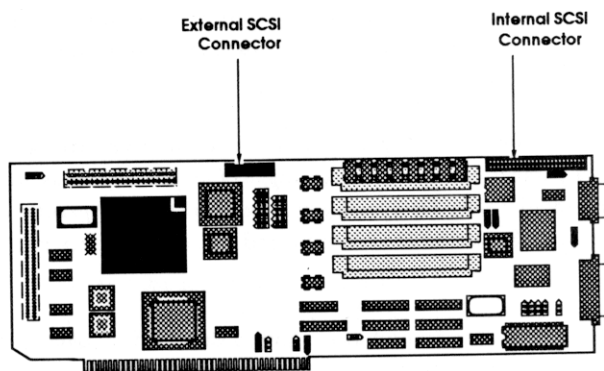

Figure 3.9 – SCSI bus connections.

Both connectors — or *headers* — are keyed in such a way that a SCSI ribbon cable can be attached in just one way (see figure 3.10).

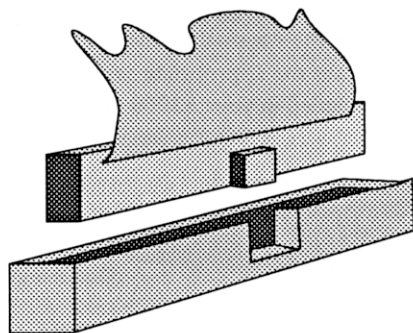

Figure 3.10 – Keyed ribbon cable and connector.

The external SCSI bus is an included option with the A2000 G-Force '040 board. If you choose to install one, a ribbon cable will attach to the 26-pin header and carry the signal lines to a rear slot mounted DB-25 connector. This external 25-pin connector can be mounted into any of the Amiga slot cover locations, or in the second CPU slot cover location (see Figure 3.11). The DB-25 connector uses a subset of the full 50-pin SCSI specification, but has become an industry standard for SCSI on other computer platforms.

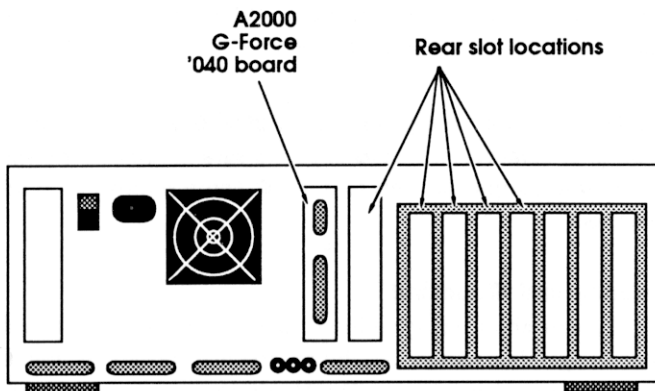

Figure 3.11 – Possible external SCSI bus locations.

If you choose to use the external connector, decide which slot you wish to use and locate the appropriate replacement slot cover plate among the items included in your A2000 G-Force '040 kit.

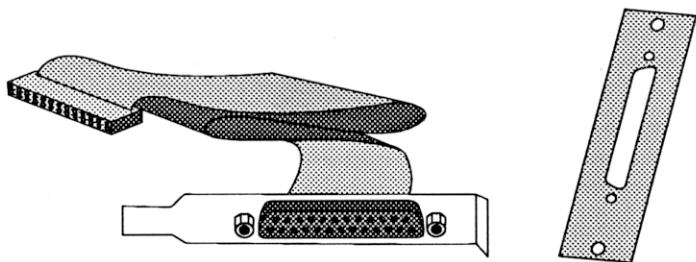

Figure 3.12 – Ribbon cable and bracket assembly (with alternate slot cover plate).

If necessary, remove the existing slot cover plate from the external SCSI connector. Use a small wrench or nut driver to unthread the nuts holding the plate to the DB-25 connector. Then, insert the DB-25 connector into the alternate slot cover plate and replace the nuts.

With the proper slot cover plate attached, locate the 26-pin header at the center of the top edge of the A2000 G-Force '040 board (see *Figure 3.9*) and attach the ribbon cable.

NOTE: If you are configuring your A2000 G-Force '040 to use an internal or external SCSI hard drive, be sure to remove the shorting block from jumper J4. This tells the G-Force board that a drive is attached.

Cabling and Mounting

We are now about ready to install the G-Force Combo board into your Amiga. For some users, this process may include the installation of one or more hard drives. The Hardware Installation chapter that follows will discuss attaching hard drives to the 50-pin ribbon



connector on the SCSI controller's internal bus. Appendix A, at the back of this book, describes various procedures for installing hard drives into the A2000.

When the A2000 G-Force '040 board is installed, the external 25-pin DB connector will extend out of the Amiga's expansion slots, providing a plug-in entry point for standard external SCSI devices. These devices usually employ a 25-pin DB to 50-pin Centronics-type cable, shielded against radio frequency interference.

Before you can proceed much further, however, you must physically install the A2000 G-Force '040 accelerator board into your Amiga. That is the subject of *Chapter 4*.

CHAPTER 4.

HARDWARE INSTALLATION**“What you need”**

You will need a medium sized cross-point screwdriver to install the A2000 G-Force '040 board.

Installation procedure

This chapter will present the necessary steps to follow when installing a G-Force board into an Amiga A2000. It is not meant to supercede any disassembly/assembly instructions provided by Commodore.

- 1) Remove the screws from the computer's cover. There are 5; one at top center on the rear panel, and two along the bottom edge of each side.

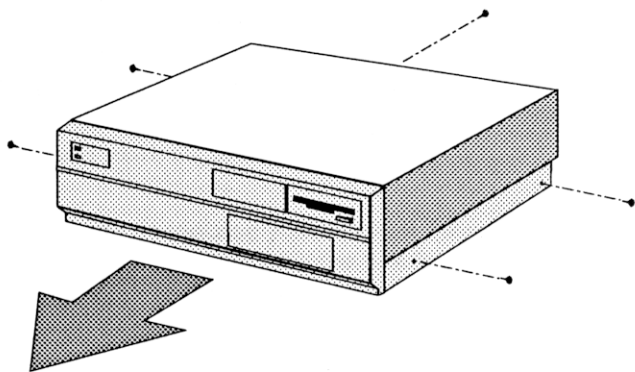

Figure 4.1 – A2000 cover screws

- 2) Remove the cover by pulling forward and away.

Now we are ready to actually install the accelerator board into the Amiga A2000. **Observe all previous cautions concerning electrostatic discharge and damage to the board.**

The A2000 G-Force '040 board uses the A2000's Processor Direct slot (see Figure 4.2). This is the multi-pin bus connector closest to the Drive Stage. There is only one way the board can fit into this slot.

- 3) Remove 2 screws and cover plate from rear panel (see Figure 4.2).

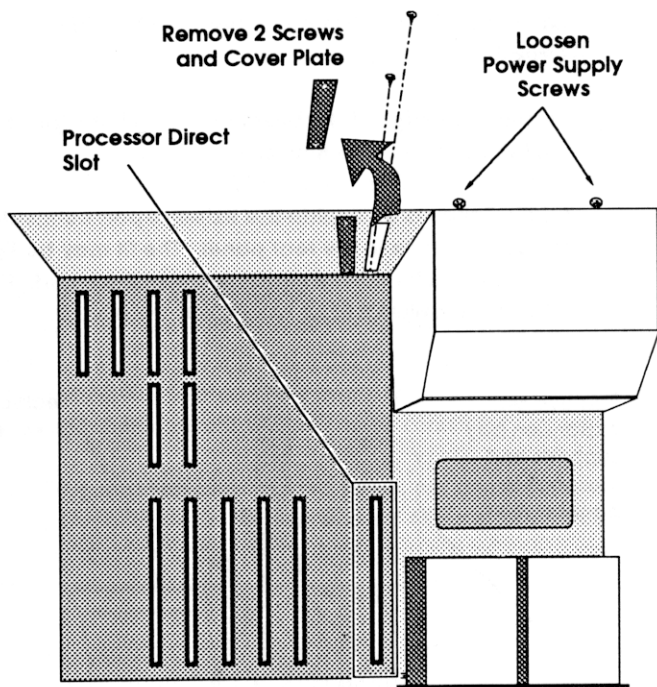

Figure 4.2 – Processor Slot location.

NOTE: GVP accelerator cards have external connection ports that protrude behind the CPU slot. IT MAY BE DIFFICULT TO INSTALL THE BOARD WITHOUT FIRST LOOSENING SOME OF THE AMIGA'S CASE SUPPORTS.

- 4) Locate the two upper screws that secure the power supply to the Amiga's rear panel. Loosen these and any other screws that prevent the rear panel from flexing (see *Figure 4.2*).

If there is an expansion bay support rod connected between the front and rear panels, remove it (*Figure 4.3*).

- 5) Locate the G-Force board into the CPU slot (closest to the *Drive Stage*).
- 6) Fit the front edge of the board into the plastic guide on the front panel of your Amiga.

NOTE: Take care to guide the external port connectors through the hole in the rear panel. The fit may be tight and may require careful manipulation of the board. **FLEX OR PRY THE AMIGA'S REAR PANEL, NOT THE BOARD.**

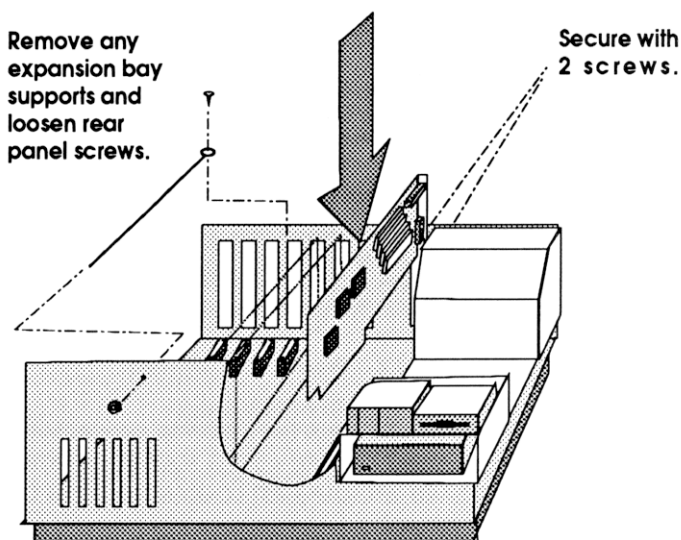

Figure 4.3 – Installing the A2000 G-Force '040.

- 7) Take care that the G-Force accelerator's edge connector and the Processor slot are properly aligned. Press the board firmly into the CPU slot. **Do not overstress the motherboard.**
- 8) Secure the board with the rear-panel cover plate screws.
- 9) Connect the leads from the Amiga's hard drive indicator light to the three-pin jumper marked LED (CN6) on the top, front-most corner of the A2000 G-Force '040 board.

Note that the center pin of this jumper is ground. Match the black wire from the Amiga's indicator light lead with this center pin. The red wire may connect with either the front or back LED jumper pin.

SCSI Bus Connections

If you have any internally mounted SCSI hard drives, thread the 50-pin ribbon cable to the internal SCSI bus connector at the back top edge of the A2000 G-Force '040 board (*Figure 3.9*). This connector is keyed and should permit the cable to be connected one way only.

If your 50-pin ribbon cable is NOT keyed, pay particular attention to the location of pin one (*usually marked directly on the cable*), and make sure that it corresponds with pin 1 of the SCSI bus connector (*marked with a "1" in white ink on the G-Force circuit board*).

If you are installing the external SCSI connection port, you should already have mounted the 26-pin header and ribbon cable as described in Chapter 3. Locate a vacant expansion slot and remove its cover (*see Figure 4.4*).

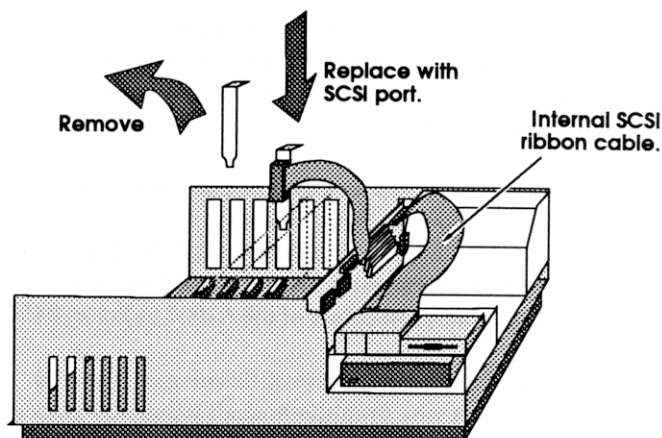

Figure 4.4 – SCSI port connections.

NOTE: If you are connecting hard drives or other devices to the A2000 G-Force '040's SCSI controller, be sure you have properly configured the unit ID numbers and terminating resistors on each device (Refer to Appendix A for more details).

- 10) Replace any brackets and tighten any screws removed during the installation process. Replace any other boards you may have removed and, finally, the Amiga's case.

Cooling Fan

Each A2000 G-Force '040 board is shipped with a heat-sink/cooling fan assembly attached directly to the 68040 chip.

WARNING: It is important that this fan be powered and operating.

- 11) The power lead from the cooling fan attaches to a hard drive-style nylon power connector (see Figure 4.5). It includes a "Y" pass-through, so that no hard drive connections will be lost.

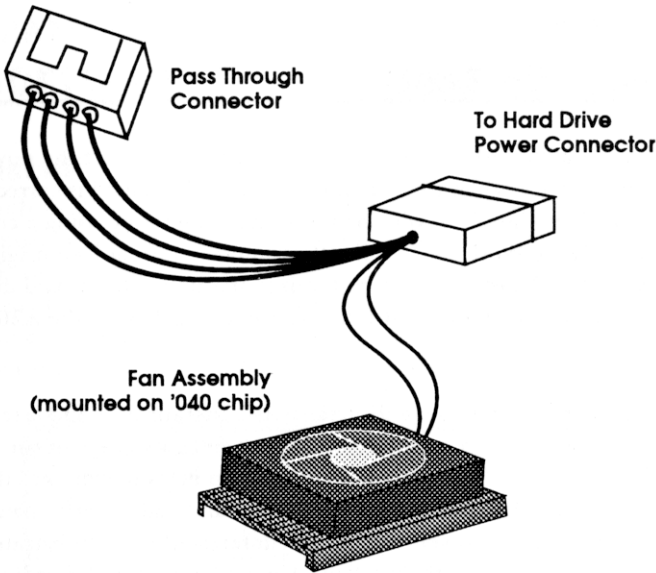

Figure 4.5 – '040 cooling fan with “Y” connector.

- 12) With the A2000 G-Force '040 board installed, thread the cooling fan's power lead up between the G-force board and the Power Supply and Drive Mount platform.
- 13) Locate an unused hard drive power connector and plug the cooling fan lead into it. If all the A2000's hard drive power connectors are in use, remove one from a hard drive and replace it with the cooling fan's pass-through connector.

When you have completed the installation process, proceed to the Power Up Test described in *Chapter 5*.

CHAPTER 5.

Power Up Test

With the A2000 G-Force '040 board installed, reconnect the power and input device cables to your Amiga. If the '040 board is correctly configured and installed, you should be able to boot up using a copy of your original Workbench disk. We recommend using your original Workbench disk instead of any customized startup floppy or hard disk, since this has been tested and found to work reliably with the A2000 G-Force '040.

In the next chapter, we will discuss the installation and use of particular software that allows you to take full advantage of the G-Force accelerator. At that time, certain system files on your hard disk will be updated for maximum compatibility and added performance. For the present, however, we are only interested in demonstrating that the board is correctly installed. Simply booting under ordinary Workbench control is sufficient for this task.

CAUTION: If, for any reason, your machine does not boot normally, power down immediately. Disconnect the power cables and reinspect your work. Make sure to check the following items:

- 1) The A2000 G-Force '040 board is correctly placed and firmly seated into the Processor Direct slot.
- 2) All memory SIMMs are correctly installed.
- 3) All jumpers are correctly configured per the description in Chapter 3.
- 4) All appropriate data and power cables and other expansion boards removed during the installation are reinstalled correctly and no pins are bent or broken.

When your Amiga boots and operates normally with the G-Force board installed, proceed to *Chapter 6 – Software Installation*.

CHAPTER 6.

SOFTWARE INSTALLATION

Installing Software

Each G-Force '040 board is shipped with a 3.5" floppy disk containing an installation program and a number of important utilities for use with the G-Force accelerator. Boot your Amiga from your normal system disk (*most likely a hard drive*), and then insert the G-Force floppy disk. When it appears on the Workbench, double-click the icon representing the G-Force '040 distribution disk.

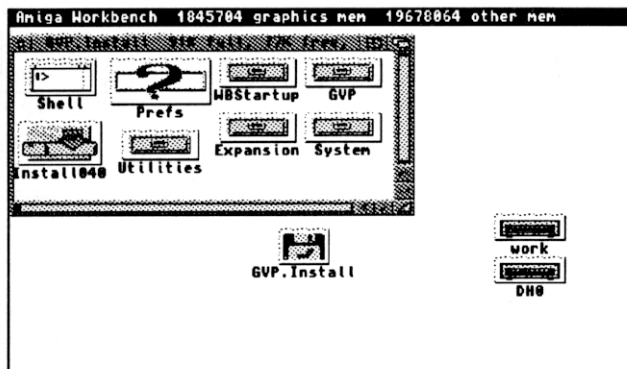

Figure 6.1 – Contents of G-Force distribution disk.

In the window that opens, you will see an icon for the installation program and several drawers, one of which contains the A2000 G-Force '040 support software. There may also be a *ReadMe* file containing any late-breaking information that may have developed since this manual was printed. Before proceeding, check this file. It may be read by clicking twice on its icon. Doing so loads *More*, the text reader program.

The Install040 program will copy the utility files to your hard disk and offer to edit the file *s.startup-sequence* for you. Refer to *Chapter 7 – Using Software*, for a complete description of the included utilities.

Install040

The Install040 program uses a new tool called *Installer*, provided by Commodore. For those who have not seen an AmigaDOS Installer before, it is designed to automate and simplify the process of adding new software to your system. Installer provides a standard point-and-click way for the novice to send every program or data file to its appropriate location.

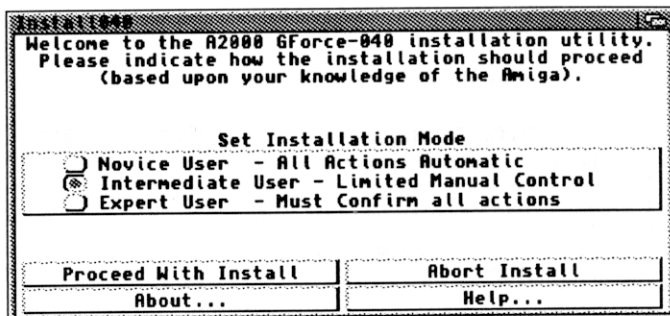

Figure 6.2 – Installer window.

Workbench users can start the automated procedure by double-clicking the Install040 icon. Respond to the prompts as they are displayed. Note that you may choose the level of control required: Intermediate or Expert. If, at any time, you don't know how to proceed, click the help button and an appropriate explanation will be displayed.

If you are still unsure about what Installer will do to your system, use the “practice” mode first. Practice lets you monitor each step of the installation without actually writing the data to your system disk. After completing the practice dry-run, you can elect to perform the installation for real.

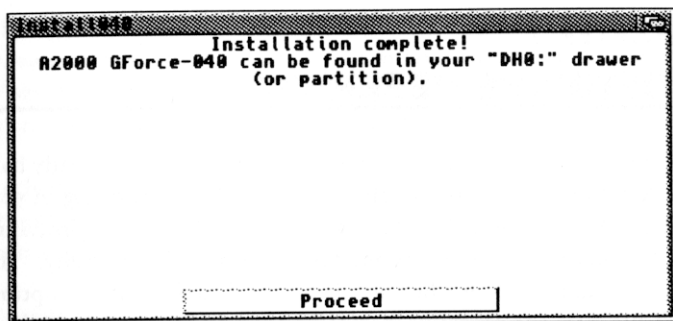

Figure 6.3 – Installation complete.

Having accomplished this task, software installation is now complete. If you reboot at this time, your Amiga will come up under full 68040 control. All included software will be fully documented in *Chapter 7 – Using Software*. Proceed to that chapter to learn how to fully optimize your G-Force accelerator.

CHAPTER 7.

SOFTWARE REFERENCE

By the time you have reached this chapter, you should already have the A2000 G-Force '040 accelerator board up and running in your Amiga. You will already have covered the procedures for installing the G-Force support software and testing its basic functionality. This chapter will provide further details on the functioning and options available from the programs included on the *GVP.Install* distribution disk. While most users will not often need to resort to this chapter, we suggest you read it thoroughly to gain a fuller understanding of the different operating modes available.

FastPrep 2.0

Any time you wish to add hard drive resources to your system (or wish to change the configuration of any existing hard drive), you will use the FastPrep 2.0 hard disk preparation utilities. These are completely documented in an accompanying manual. Refer to that manual before attempting to use this program.



GVPcpuCtrl

GVPcpuCtrl is a new standard utility for controlling all GVP accelerators. It has user specifiable flags that condition it to work with the A2000 G-Force '040 board, our line of '030 Combo boards, and other peripherals.



GVPcpuCtrl functions primarily to enable or disable accelerated processing and to map the Amiga system ROM into on-board 32-bit memory. ROM mapping results in a significant increase in processing speed.



The GVPcpuCtrl utility can be executed as part of the *s:startup-sequence* script; run from the Shell; or launched from Workbench. When run from the CLI or Shell, GVPcpuCtrl performs different operations, depending on the parameter supplied.

Each time the program is run, it will accept any of four possible arguments. These may be appended singly or as a command string with a space character separating arguments:

Template:

```
GVPcpuCtrl (argument) (argument) <return>
```

Arguments:

FASTROM – Copies the contents of system ROM into on-board FAST memory and resets ROM vectors to point to this new copy.

NOFASTROM – Resets ROM vectors to point to the Amiga's ROM chips and frees any FAST memory previously reserved for FASTROM.

BOOT68000 – Attempts to reboot the computer into native 68000 operation.

MoveSSP – Resets the system Supervisor Stack Pointer vectors to point to an area of 32-bit RAM. All processor stack operations will execute much faster in this space.

NoMoveSSP – Resets the system Supervisor Stack Pointer to Amiga system (16-bit) RAM.

NOTE: We strongly recommend inserting the following command line into your system's startup-sequence. Doing so will maximize the A2000 G-Force '040's performance.



Examples:

```
GVPcPcuCtrl MoveSSP FASTROM <return>
```

Relocates the Supervisor Stack Pointer and system ROM into onboard 32-bit FAST RAM.

```
GVPcPcuCtrl Boot68000 <return>
```

Reboots the Amiga with the accelerator disabled.

GVPcPcuCtrl, when clicked from the Workbench, reboots the machine in its native processor mode. The A2000 will reboot under unaccelerated 68000 control.

GVPScsiCtrl



This program is important for several applications. You will probably need this program if you use removable media disk drives (*such as the Ricoh, Bernoulli or SyQuest cartridge systems*), and wish the computer to recognize a cartridge you insert after the computer is running.

You will also need this program if you are using SCSI devices (*such as Wangtek tape drives*) that require their “disconnect” flag to be turned off. Such devices cannot have this flag set by FaaastPrep.

There are four options for using GVPScsiCtrl from the CLI. There is one option for using this program from the Workbench.

Workbench:

When the GVPScsiCtrl icon is double clicked using the Workbench interface, a command is sent to the GVP SCSI controller that causes it to search for any changed volumes (*such as SyQuest cartridges*) to mount. This functions essentially the same as using the -m CLI option described below.



CLI Template:

```
GVPScsiCtrl (option) <return>
```

Variants:

```
GVPScsiCtrl -m
```

The argument `-m`, in this case, stands for *“mount.”* This form of the command will poll all known devices connected to the SCSI bus and attempt to mount any new or changed volumes it finds. Such a case might occur when inserting a new SyQuest cartridge into a previously empty drive.

```
GVPScsiCtrl -r
```

This form of the command differs from the above in that it is able to recognize hard drives or other devices that were not present at startup. An example might be a large-capacity or older drive that takes an appreciable amount of time to “spin up.” In such a case, the `-m` option would not recognize any drives that had not reached operating speed when the system booted.

The `-r` option, by contrast, forces the SCSI controller to reexamine all possible unit IDs for mountable drives. In this case, the `-r` argument stands for *“rescan.”* If the controller encounters a valid device with no mountable volume (*an empty SyQuest drive, for instance*), it will skip to the next available device.

```
GVPScsiCtrl -s
```

This form of the command functions similar to the `-m` option described above. It differs from the previous form in that it will wait until all known removable media devices return successfully mounted. If it should find an empty SyQuest drive, for instance, the program will halt and wait until a valid cartridge is inserted. The argument `-s`, in this case, stands for *“sticky mount.”*



This command may be used in the *startup-sequence* to ensure that a removable media cartridge will be recognized as soon as it is inserted. In this case, the *-s* argument should be prevented from hanging up your boot sequence by using the AmigaDOS *Run* command:

```
RUN >NIL: GVPScsiCtrl -s
```

This will spawn a separate task that runs until all units are mounted; at which point it will terminate. In the meantime, the original calling process will continue to execute.

Disconnect/Reconnect

Part of the SCSI standard provides for sharing the SCSI bus among competing drives by periodically disconnecting and then reconnecting them. In this way, the SCSI controller can access one drive while another is busy filling or emptying its internal buffers. Most hard drives can be disconnected without any unfortunate results.

Under certain circumstances, however, the SCSI bus may not operate properly with disconnect enabled for every device. The usual symptoms are that the Amiga will issue “phase-error” warnings or simply hang up during a SCSI transfer.

Although hard disks can be easily prepped to automatically disable this feature, devices without a Rigid Disk Block—tape drives, for example—must be treated differently. In such instances, you can use GVPScsiCtrl to disable disconnect for individual devices.

```
GVPScsiCtrl <Unit ID> DCOFF | DCON
```

Issue the above form of the command, replacing <Unit ID> with the SCSI ID of the device in question. For instance, if a tape drive is connected as ID #6, typing the command:

```
GVPScsiCtrl 006 DCOFF <return>
```



will disable disconnect for that device. Then, whenever the tape drive is being read from or written to, no other SCSI operations will be allowed to compete. A corresponding argument:

```
GVPScsiCtrl 006 DCON <return>
```

will reenable Disconnect/Reconnect for the specified device.

Using GVPScsiCtrl

To maximize the efficiency of your GVP SCSI system, we recommend adding the following lines to your computer's startup script for execution every time you reboot. We recommend placing them toward the end of the file *s:User-Startup*.

Startup Instruction	Meaning
GVPScsiCtrl -r	;rescans the SCSI bus for slow drives
GVPScsiCtrl 006 DCOFF	;disables DC/RC for a tape drive
Run >NIL: GVPScsiCtrl -s	;wait for cartridge insertion

NOTE: The GVPScsiCtrl command must be present in your current command path for these instructions to work. You may, alternately, provide a full path before each GVPScsiCtrl command.

The second instruction (GVPScsiCtrl 006 DCOFF) assumes the presence of a tape drive unit as ID 6. If you have a tape drive with some other Unit ID designation, use that one, instead. If you have no tape drive, omit the command altogether.

GVP Extended Input/Output ports

The A2000 G-Force '040 board has its own serial and parallel ports. These will be most immediately useful to programs—such as BBS systems, telecommunications software, and print spoolers—that can be configured to access them. There are three different ways that your software can make use of the G-Force board's ports. The most flexible way requires that your software—a telecommunications program, for instance—be individually configured to address the GVP port directly.

The next most desirable method involves the use of logical device designations `GVPPar0:` and `GVPSer0:`. These are managed by a “handler” resource in the system `L:` directory. Some programs—print spoolers, for instance—allow you to specify such a logical designator as the output device. Finally, for software that cannot be reassigned in any other way, GVP provides a means of intercepting, on a system level, all calls to the Amiga’s own parallel or serial devices and redirecting them to the corresponding GVP ports. The tool for achieving this is called *GVPIOControl*.

GVPIOControl



GVPIOControl

Unless specifically written for an expandable system, not all software will be able to access the A2000 G-Force '040's ports. Many current programs expect to use only the Amiga's ports through the `serial.device` and `parallel.device` drivers located in your Amiga's `Devs:` directory. *GVPIOControl* allows you to intercept ordinary system calls to the Amiga's serial or parallel ports and have them redirected to the ports on the G-Force '040. In this way, you can make these ports the defaults for *all* current software.

Click twice to open the Prefs drawer and click twice on the *GVPIOControl* icon to launch the program.

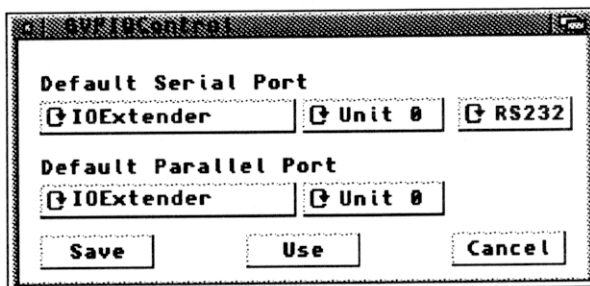

Figure 7.1 – *GVPIOControl* window.



Default Serial Port

Default Serial Port

IOExtender Unit 0 RS232

Clicking on the Serial Device button will toggle between Amiga and IOExtender settings. When you select Amiga as the default, the system will operate normally, sending all system calls to the Amiga's built-in serial port connector.

When you select IOExtender (*the A2000 G-Force '040 board uses the same ROM code as does our companion IOExtender product*), all system calls to the Amiga's serial port will be intercepted and rerouted to the serial port on the G-Force board. This setting requires that you make two additional selections: Unit Number and Port Configuration (*RS232/MIDI/AUX*).

Unit Number Selection

Since the A2000 G-Force '040 board has only one serial port, the Unit Number selector will default to 0. It should only be changed if you have additional GVP IOExtender expansion boards installed in your system. In this case, Unit 1 is skipped, and any other serial ports are referenced in sequence as Unit 2, Unit 3, Unit 4, etc. Clicking on the Unit Number button will cycle upward through all available Unit numbers. Holding down the Shift key while clicking will cycle backward through the available Unit numbers.

Serial Port Configuration Selection

The GVP extended serial port is designed to be electrically compatible with the RS-232 communication standard, MIDI serial specifications and an Auxiliary configuration reserved for future GVP products. Clicking on the Configuration button will cycle through RS232, MIDI and AUX settings. Holding down the Shift key while clicking will cycle backward through the settings.



Default Parallel Port

Default Parallel Port

IOExtender

Unit 0

Clicking on the Parallel Device button will toggle between Amiga and IOExtender settings. When you select Amiga as the default, the system will operate normally, sending all system calls to the Amiga's built-in parallel port connector.

When you select IOExtender, all system calls to the Amiga's parallel port will be intercepted and rerouted to the parallel port on the G-Force board. This setting requires that you make one additional selection: Unit Number.

Unit Number Selection

The A2000 G-Force '040 board has only one parallel port, so the Unit Number selector will default to 0. It should only be changed if you have additional GVP IOExtender expansion boards installed in your system. In this case, Unit 1 would address the parallel port on the first IOExtender board, and any other parallel ports on additional boards are referenced in sequence as Unit 2, Unit 3, Unit 4, etc. Clicking on the Unit Number button will cycle upward through all available Unit numbers. Holding down the Shift key while clicking will cycle backward through the available Unit numbers.

Exiting GVPIOControl

When you have set the GVPIOControl parameters to your liking, you can click the Save button to record them as the default system configuration. These settings will then become operative each time you reboot your system. If you do not want the settings to be permanently recorded, click the Use button. The configuration will remain operative only until your next system reboot. If you decide to exit the program without making any changes, click the Cancel button and any parameters that were altered will be restored to their original condition.



Effective Use

As mentioned, GVPIOControl is the least flexible method for using the ports on your A2000 G-Force '040 board. Since it wedges itself into the Amiga's operating system and intercepts all calls on a system level, it effectively substitutes the GVP ports for your Amiga's ports. It does not necessarily permit one program to use the GVP ports while other programs are free to use other ports.

The only way to actually use multiple serial and multiple parallel ports simultaneously is through individual applications programs that permit their input and output ports to be specified either as logical devices (*GVPPar0*; *SER*; etc.) or as physical devices (*parallel.device*, *gvpserial.device*, etc.).

GVPSerial Preferences



The serial port on the A2000 G-Force '040 board (and any other serial ports on additional GVP IOExtender expansion boards) can be controlled through a preferences utility that functions much the same as the standard Workbench preferences utilities. This program is automatically installed in your Prefs drawer by the Install040 program.

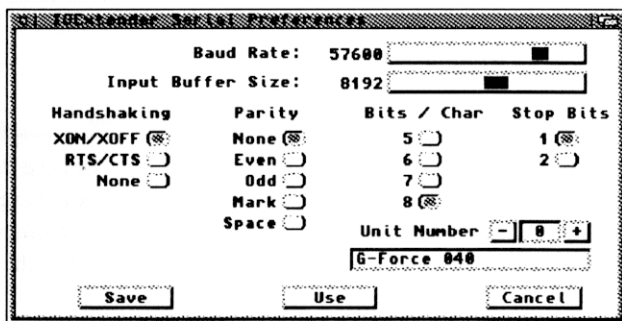

Figure 7.2 – GVPSerial preferences panel.



Baud Rate

Baud Rate: 57600 

The serial port on the A2000 G-Force '040 board is capable of a much wider range of transmission speeds than the standard Amiga serial port: From 110 to 625000 bits per second (*bps or baud*). Drag the slider to set the serial port's transfer rate. Possible increments are 110, 300, 1200, 2400, 4800, 9600, 19200, MIDI (31250), 38400, 57600, CUSTOM and MAXIMUM.

In order to set your own custom transmission rate, adjust the Baud Rate slider until CUSTOM is displayed. Then, locate the Miscellaneous Menu (*by holding down the Right Mouse Button and moving the mouse pointer up to the top of the screen*). When you select the Set Custom Baud Rate menu item, a requester window will open. This requester contains a text-entry field into which you can type any baud rate desired.

Note that you may specify only transfer rates that fall within the range of possible values (*110 to 625000 bps*). If the GVPSerial utility is unable to deliver exactly the rate requested, it will report the actual rate achieved and the percent of variance from the specified value.

Input Buffer Size

Input Buffer Size: 8192 

Unlike the Amiga's standard serial port, the A2000 G-Force '040's serial port has hardware buffers of 16 bytes each for receiving and transmitting. It also has a variable software buffer where incoming data can be cached while your application is busy doing other things.

You can set the Input Buffer Size by adjusting the slider until the desired value is displayed. Acceptable values range from 512 to 65,536 bytes. A 4 Megabyte G-Force '040 can easily support a 16k serial buffer.

Handshaking

Although serial devices are two-way communicators, information can only be passed through sequential exchanges. One device *talks* while the other one *listens* and vice versa. Handshaking protocols are the means by which two serial devices determine which talks when.

Handshaking

XON/XOFF

RTS/CTS

None

- XON/XOFF is a software-based protocol. When a XON character is received, the sending unit knows to begin transmitting. When a XOFF character is received, the sender stops transmitting and waits for the next XON signal.
- RTS/CTS is a hardware-level protocol. When compatible devices are connected with the proper cables, transfers will be managed entirely through the circuitry built into the equipment. The sending device transmits a *Request To Send (RTS)* signal and waits for a *Clear To Send (CTS)* reply.
- Some unusual equipment may not require handshaking protocols at all. When None is selected, data will be sent as quickly as the hardware permits. If something on the other end interferes with the orderly processing of data as it is received, some information will be lost.

Parity

Parity is a method of checking for errors while data is being transmitted. A Parity bit is used to adjust each transmitted character to meet these criteria:

Parity

None

Even

Odd

Mark

Space

- NONE means that no parity bit is used.
- EVEN means that the total number of 1 bits in each transmitted character is even. If the source data contains an odd number of 1 bits, then the Parity bit will be set to 1. If the source data has an even number of 1 bits, the Parity bit will be 0.



- ODD means that the total number of 1 bits in each transmitted character is odd. If the source data contains an even number of 1 bits, then the Parity bit will be set to 1. If the source data has an odd number of 1 bits, the Parity bit will be 0.
- MARK means that the parity bit will always be set to 1.
- SPACE means that the parity bit will always be set to 0.

Bits/Character

Bits/Char (*Bits per Character*) tells your device how many data bits each character contains. The most common number of bits/character is 8. Many devices still use 7, and your A2000 G-Force '040 will even support older hardware that relies on 5 or 6 bits/character.

Bits / Char

5

6

7

8

Stop Bits

Stop Bits are used to tell a device to stop sending information down the data path. Some devices require 1 Stop Bit; others expect 2.

Stop Bits

1

2

NOTE: If you configure your serial device to send 5 data bits per character, the Stop Bit choices automatically change from 1 or 2 to 1 or 1.5.

Unit Number

As mentioned above, the A2000 G-Force '040 board has only one serial port, numbered Unit 0.

If you have additional GVP IOExtender boards installed in your system, each serial port will be assigned an incrementally higher Unit number. The Unit Number selector in the GVPSerial utility provides a method for making a unique setup configuration for each separate serial port.

Unit Number

- 0 +

G-Force 040

As you cycle through the possible Unit Numbers, the status line beneath the selector will display the identity and location of the selected port.

GVPSerial Menus

The GVPSerial preferences utility has three menus, in addition to its onscreen buttons and selectors. These menus make it possible to create and save many different configuration presets that can be loaded and used as needed.

Project Menu

- Open loads a predefined settings file and configures the selected serial port accordingly.
- Save As... When you click the Save button in the GVPSerial preferences utility, the settings become a part of the utility's default configuration. The Save As... menu item allows these settings to be saved as a non-default file. This can be reloaded at any time using the Open menu.
- Quit provides a menu-based method for exiting the GVPSerial preferences utility.



Edit

Each GVPSerial preferences project icon contains two sets of configuration data in the form of Tooltypes: A set of factory defaults and the last saved User Settings. At any time during a GVPSerial preferences configuration session, you can restore either the factory defaults or the last saved settings.

- Reset to defaults examines the GVPSerial preferences icon and restores the factory default settings encoded there.

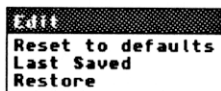



- Last Saved examines the GVPSerial preferences icon and restores the User Settings encoded there.
- Restore resets the currently selected Unit to the settings in effect prior to the most recent changes.

Miscellaneous

Miscellaneous

Set Custom Baud Rate

- Set Custom Baud Rate.

When you set the Baud Rate slider to its CUSTOM setting, you must select this menu item and type your custom transfer rate value into the text-entry field provided.

Exiting GVPSerial Preferences

When you have set the GVPSerial preferences parameters to your liking, you can click the Save button to record them into the Tooltypes for the GVPSerial preferences utility icon. These settings will then become operative each time you reboot your system. If you do not want the settings to be permanently recorded, click the Use button. The configuration will remain operative only until your next system reboot. If you decide to exit the program without making any changes, click the Cancel button and any parameters that were altered will be restored to their original condition.

CPU

You can dynamically control the A2000 G-Force '040 board's instruction and data caches using the AmigaDOS command *CPU*. This CLI instruction is documented in the *Commodore AmigaDOS Manual 3rd. Edition*.

G-Force users should note that some CPU options (e.g.: *FASTROM*) will have no effect on the G-Force board. Use the *FASTROM* option of *GVPcPuCtrl*, instead. Also recall that the '040's Burst mode can only be enabled after installing the correct amount of memory and physically setting jumper J22 (see jumper Table 3.1 in Chapter 3).

Example:

CPU CACHE <return>

turns both instruction and data caches on.

CPU NOCACHE <return>

turns both instruction and data caches off.

CPU INSTCACHE <return>

turns on just the instruction cache.

At startup, the AmigaDOS Setpatch instruction switches on the processor's caches and Copyback mode. The CPU instruction can be used to change this condition.

GVPInfo

Another included utility is GVP's standard *GVPInfo*. This point-and-click program opens a window that lets you examine many different facets of your entire system.

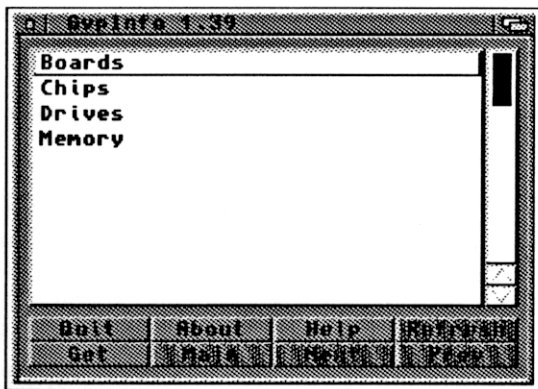

Figure 7.3 – GVPInfo window.



In the main window, you will see listed *Boards, Chips, Drives* and *Memory*. Clicking twice on any of these items will produce a new window displaying relevant information about the selected items. Each item in the new list can, in turn, be double-clicked, to produce still more information about the selected item.

GVPInfo has a special flag for CLI use. When launched from Shell or CLI as:

```
GVPInfo SPEED <return>
```

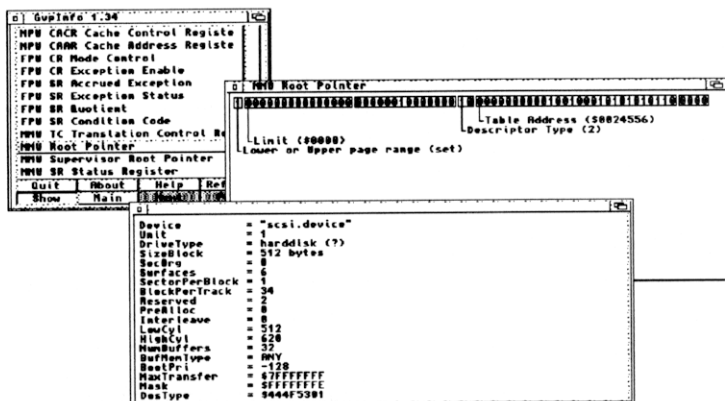

Figure 7.4 – GVPInfo displays.

the *Speed* option will run a performance test on your main processor chips and display the result.

The A2000 G-Force '040 distribution disk contains a number of other useful programs that are not documented here. Please refer to the *ReadMe* file on the disk for complete information on these other utilities. This concludes our discussion of the A2000 G-Force '040 accelerator support software. If it is correctly installed and the utilities are run, you should soon be enjoying the maximum level of performance available on any Amiga, anywhere.



CHAPTER 8.

THEORY OF OPERATION

Users who wish to know more about how the A2000 G-Force '040 board works will appreciate the following information:

68000 vs 68040

The Amiga 2000, as designed, uses a Motorola 68000 16/32-bit microprocessor running at a 7.14 MHz clock speed. This powerful computer chip provides basic control over all the Amiga's components. While the 68000 chip uses 32-bit "registers" internally for the representation of data, it is connected to the circuit board (*and all other external devices*) by a 16-bit wide "bus." This narrow bus architecture results in a performance bottleneck, as all 32-bit data values must be broken in half and sent out on the bus as two 16-bit "words."

The A2000 G-Force '040's MC68040 processor is a full 32-bit microprocessor. Its internal data representation uses 32-bit registers and it is connected to the other components on the G-Force board via a 32-bit wide bus. Data that can be exchanged between the 68040 and any other board components can be moved in full 32-bit words providing a 2 to 1 increase in throughput.

Clock Speed

In addition, the A2000 G-Force '040 accelerator employs its own clock running at much greater rates than a stock Amiga's. A computer's system clock determines the rate at which data can be transferred. Each time the clock crystal "beats," the processor's registers can be changed. On a stock Amiga, with a 7.14 MHz clock, that provides a maximum of 3,580,000 data movements per second. The A2000 G-Force '040 accelerator, clocked at 33 MHz, by contrast, can achieve up to 66 Million data movements per second.



Key to this performance is the “asynchronous” nature of the G-Force board’s design. A synchronous accelerator must run at some even multiple of the Amiga’s base 7.14 MHz clock rate (*e.g.*: 21.42, 35.7), interleaving its operations with the slower cycling of the Amiga bus. Asynchronous designs, like GVP’s, permit the use of faster, and more commonly available, processors. These are then free to execute their operations independently of the main Amiga bus.

Memory Addressing

The original Amiga 2000’s Motorola 68000 has a 24-bit address register. A 24-bit register can hold any numeric value from 0 through 16,777,216, and that means a maximum of 16 Megabytes of address space. 7 Megabytes are reserved by Commodore for various hardware-specific uses, leaving 9 Megabytes for use by programs and data (*1 Megabyte of this is so-called CHIP RAM*). All 9 Megabytes, by design must be reached through the 16-bit wide expansion bus. On those Amiga systems equipped with a XT or AT BridgeBoard, two of these Megabytes are required by the BridgeBoard for communication dataspace.

To provide maximum compatibility with existing hardware and software products, the A2000 G-Force ’040 board is designed to locate all its memory resources outside this base 8 Megabyte “Auto-config” address space. Since the G-Force board can hold much more than 8 Megabytes, its RAM is mapped and used as “Extended memory.” A special circuit on the G-Force board manages system access to this Extended RAM and provides a completely transparent interface to most correctly written programs. This ensures that any memory physically mounted on the A2000 G-Force ’040 board will be addressable by the processor as a full 32-bits wide and can be used first for program execution and data storage.

Every A2000 G-Force board also contains its own 32-bit bus connectors, allowing other 32-bit expansion products to talk directly to the 68040 and GVP FAST RAM. In the future, GVP may market expansion products that use this 32-bit bus.

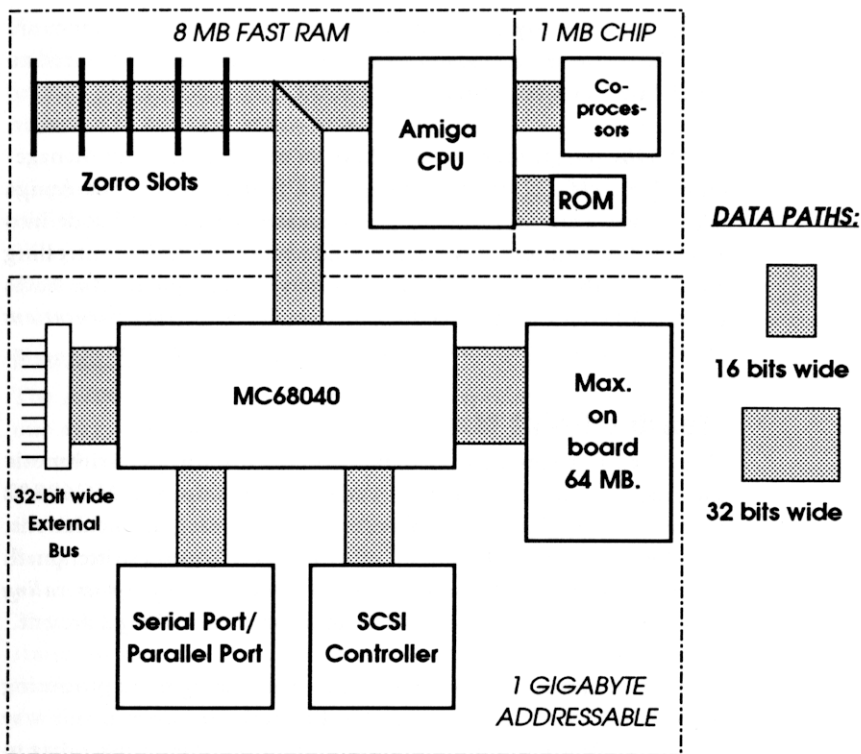

Figure 8.1 – A2000 G-Force '040 board block diagram.

SCSI Controller

The A2000 G-Force '040 accelerator employs Direct Memory Access (DMA) technology to read and write data directly from and to RAM. The SCSI controller built into the G-Force board has a 16-bit wide data path to the unit's 32-bit memory resources.

68040 features

In addition to its basic processing "machinery," the Motorola 68040 chip contains two 4 kilobyte temporary storage areas called "caches."



The most frequently used Instruction and Data memory locations are retained in these caches, reducing the amount of time required to “fetch” their contents from external RAM.

All 68040s (*except the 68EC040*) have an onboard Memory Management Unit (*MMU*) that can be used to remap areas of the Amiga address space and, for instance, relocate the system ROM code into fast, 32-bit memory. GVP has provided its own RAM controlling circuitry on the G-Force '040 board to serve this purpose. This leaves the 68040 chip's MMU free for other applications (*implementations of the UNIX operating System, software debuggers, etc.*) to use.

Floating Point Math

The 68030 processor is designed to perform integer arithmetic internally. Motorola provides a companion chip, the MC68882 Floating Point Unit (*FPU*), to take over non-integral calculations, thereby freeing the 68030 to do other things. Properly written math intensive operations (*like recalculating a spreadsheet or graphics scaling and ray tracing*) will execute many times faster with a 68882 present.

The 68040 processor, by contrast, combines floating point processing directly on the chip. Integrating the math circuitry in this way decreases calculation times by eliminating the need to transfer data to an external math handling resource. All of the standard 68882 arithmetic functions are performed by this on-board facility, with the exception of transcendental trigonometric operations. These must be emulated through software. The G-Force installation disk contains a special *68040.library* that provides this software support.

Relocating System ROM

Most of the key instructions that the Amiga Operating System uses to process data reside in a set of Read Only Memory (*ROM*) chips on the Motherboard. When a program makes a library call, the computer looks up the proper piece of code in the system ROM. Unfortunately for most operations, ROM calls are not terribly efficient. The ROM chips, themselves, are much slower than Random Access Memory.



Fortunately for A2000 G-Force '040 board users, the entire contents of the System ROM can be copied into 32-bit RAM dataspace. Then, when a program calls on ROM for a key operation, the entire 32-bit value can be retrieved with a single access.

Copying the System ROM is easily accomplished using the *GVPCpuCtrl* utility (included on the GVP.Install distribution disk). The procedures for doing so are described in *Chapter 7 – Software Reference*.

Parallel and Serial Ports

The A2000 G-Force '040 board includes special circuitry that adds one extra serial and parallel port to your Amiga's complement of communication ports. The serial port has the benefit of two 16 byte hardware caches to buffer incoming and outgoing data. These make the GVP serial port considerably more reliable than the unbuffered Amiga serial port.

The GVP parallel port can be jumper-configured as either an Amiga standard or PC-compatible parallel port, providing expanded flexibility in connecting scanners, plotters, printers and other parallel devices. Both the serial and parallel ports can be addressed directly by retargetable software, or as logical devices, through GVP's software handler. In those cases where no other software access is possible, GVP also provides a means of redirecting Amiga system calls to the G-Force board ports.

G-Force Board Operation

Upon power-up or system reset, the 68040 acquires control of the Amiga's processor bus by requesting bus access from the 68000. Once in control, the G-Force '040 board is free to run the machine, fetching instructions and data at its own clock rate, and making use of its internal caches and 32-bit data path. Since the G-Force board never surrenders bus control, the 68000 is prevented from reclaiming mastery over the machine.



In order for the A2000 G-Force '040 board to replace the 68000 without conflict, it must be able to emulate 68000 control signals and timing, and to disable 68040 instruction and data caches where necessary. [You will recall that the A2000 G-Force '040 board uses an asynchronous clock rate.]

GVP provides a custom circuit to synchronize all accesses to the Amiga's processor bus. Operations that needn't interface with the main Amiga bus (*e.g.: calculations and DMA data transfers*) can be performed at the maximum speed of the processor. Operations that require cooperation from the Amiga's system bus (*e.g.: printing through the Amiga's parallel port or display of graphic imagery*) will be synchronized to the Amiga's bus speed.

Similarly, it is sometimes necessary to switch off the 68040's internal caches when working in conjunction with the Amiga's custom graphics chips. These chips have the ability to directly modify the contents of CHIP RAM. Consequently, any information that may have been cached by the 68040 may no longer be correct if the custom chips have modified the contents of those addresses. The A2000 G-Force '040 board contains another custom circuit to keep track of and control caches under these circumstances.

Backward Compatibility

Finally, the A2000 G-Force '040 board can be disabled altogether whenever a particular program requires true 68000 functionality. While most current software is flexible enough to make use of more sophisticated processors, some games still assume that they are talking to a stock 68000. For such instances, GVP provides a Workbench program called *"GVPCpuCtrl"* that allows booting under 68000 control. When this is done, the G-Force board effectively disappears, taking with it any memory and hard drive resources it may contain. Other memory and hard drives installed in Zorro expansion slots will still be present and usable by the 68000 based system.



APPENDIX A.

HARD DRIVE INSTALLATION

Before you Begin

Before installing SCSI hard drives in your system, you must make sure that each device is correctly configured. This involves determining each unit's unique ID number and may also involve the addition or removal of termination resistors.

The SCSI bus is a high-speed, two-way communications channel between the GVP controller and up to 7 SCSI devices. Any or all of the 7 attached units may be active and communicating at once, with the controller determining which one gets the bus at what time.

SCSI Unit ID Numbers

In order to keep track of all the devices attached to the SCSI bus, each one must have a unique ID number. Usually, this ID number corresponds with its position in the chain of devices, but not necessarily. Acceptable SCSI ID numbers are 0-7. The GVP controller, itself, will always be designated as ID #7. The remaining available ID numbers are 0-6. Most users will start numbering their additional SCSI drives from 0 (*e.g.*: *DH0*;, *DH1*;, *CD2*;, *etc.*).

Every device designed to meet the SCSI specification must provide some way of changing the ID number of the device. Hard drives usually employ a set of jumper pins for this purpose. There are a number of different jumper configurations employed by the different hard drive manufacturers, so we will not attempt to describe a standard method here. Refer to the document supplied with your particular brand of hard drive, or consult with your GVP dealer.

Terminating Resistors

Another requirement of the SCSI bus is that it must be electrically terminated on each end. Most SCSI devices will have some means of

installing or applying resistors to electrically terminate the bus connectors. If several devices are attached together in “daisy chain” fashion, then both the first and last units in the chain must be terminated, but any terminating resistors on any intermediate devices must be removed or disabled (*Figure A.1*).

Again, there is no industry standard method for installing termination resistors. Most hard drives employ a series of socketed, comb-like components called “resistor packs.” These are usually found directly adjacent to the 50-pin SCSI bus connector on the drive, itself. Refer to the document supplied with your drive for further details.

NOTE: The GVP SCSI controller, itself, provides termination for the head end of the bus. If several devices are attached to the external 25-pin connector, only the last device on the bus should be terminated (see Figure A.2).

After determining how many hard drives you wish to install and deciding whether they will be attached to the GVP controller’s internal or external SCSI bus connector, allocate an appropriate ID number to each and set its Unit ID jumpers accordingly. Then, remove all terminating resistors on each device except the last drive that will be connected to the external bus connector. When this is completed, you are ready to install the hard drives.

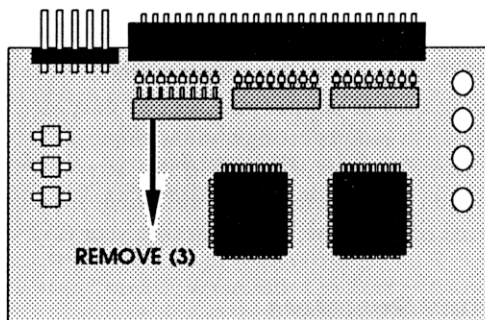

Figure A.1 – Location of terminating resistors on typical hard disk drive. May vary with manufacturer.

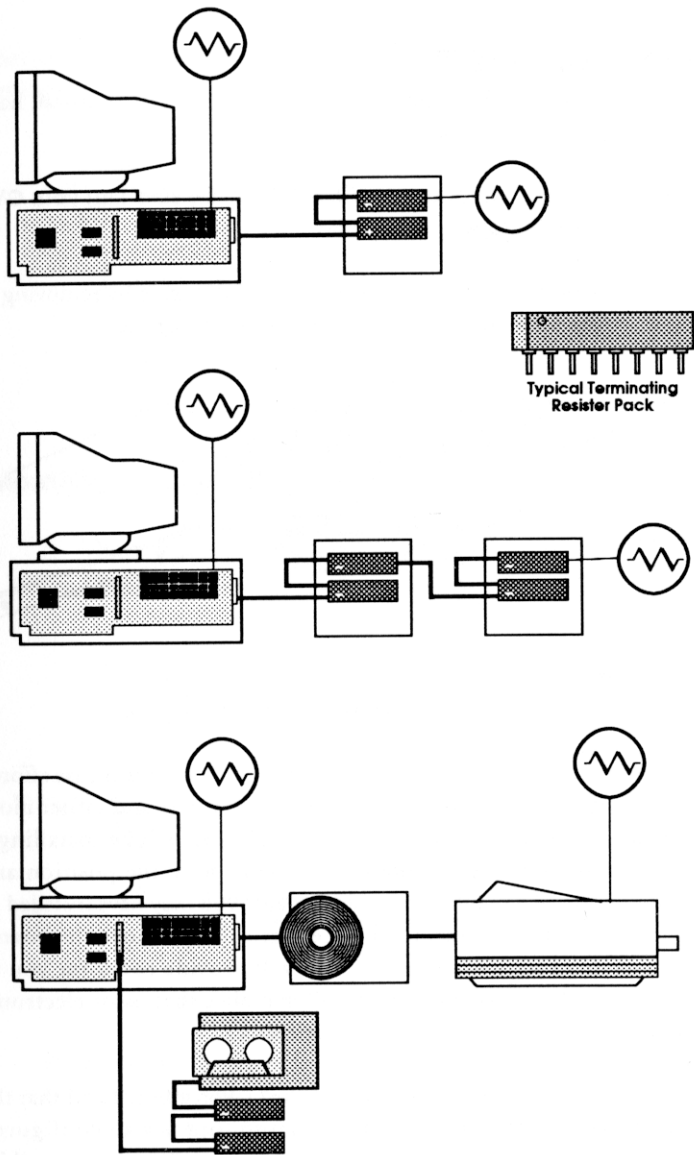

Figure A.2 – SCSI bus connections and termination.



“What you need”

You will need a medium sized cross-point screwdriver to install hard disk drives in your Amiga.

NOTE: Any time you add a SCSI hard drive, be sure that your GVP SCSI controller is properly configured.

- 1) If necessary, prepare the Amiga A2000's case by removing the 5.25" plastic filler plate from the front panel.

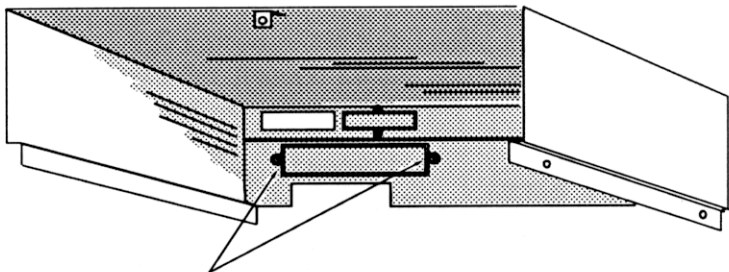

Remove 2 screws.

Figure A.3 – Remove drive bay cover plate.

The Amiga drive mounting stage is a two-tiered platform that affords a relatively easy access to the upper 3.5" drive bays and rather more difficult access to the lower 5.25" bay. If you will be installing a device in the lower bay, take some time to note the position and configuration of any other expansion boards you may have installed in your system. Having recorded these particulars, remove the boards and put them somewhere safe. This will provide room for you to work around the lower drive bay. **Remember that most electronic components are easily damaged by static shock.**

Be sure you have correctly configured the G-Force board and that the hard drive (*or other device*) you are mounting is also configured appropriately. This involves setting its jumper IDs and, possibly, installing or removing terminating resistors. Refer to the documents

that came with your drives for correct procedures to make these settings.

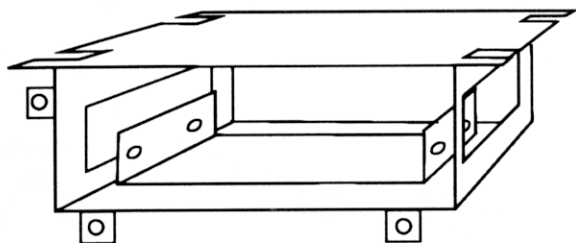

Figure A.4 – Amiga 2000 Hard Drive Stage.

Mounting a 3.5" hard drive

- 2) The upper tier of the Hard Drive Stage is attached to the lower by two screws on either side.

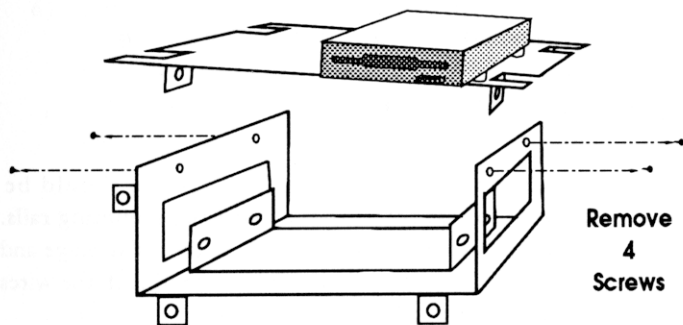

Figure A.5 – Upper tier removal.

- 3) Install a 3.5" drive in the vacant upper bay. Orient the drive so that its 50-pin connector is pointed toward the rear of the computer. Locate the four mounting holes on

the underside of the drive with the holes in the upper drive tier. The spacing for these holes is industry standard and the drive will fit if it is oriented correctly.

- 4) Secure the drive with four screws.

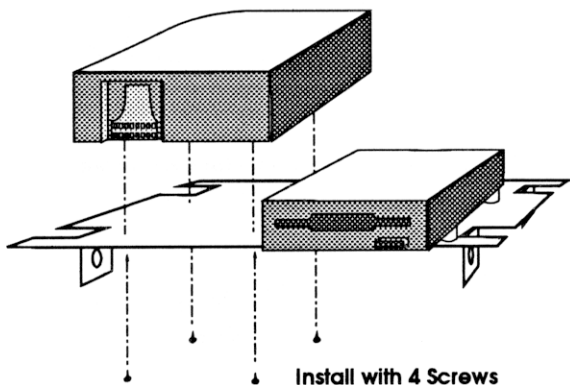

Figure A.6 – Upper tier drive installation.

Mounting a 5.25" hard drive

- 5) The upper tier of the Hard Drive Stage should be removed to ease access to the lower tier mounting rails. remove two screws from either side of the Drive Stage and lift off the upper tier. Be careful not to disturb the wires connected to your Amiga's floppy drive.

A 5.25" hard drive or other SCSI device (*e.g.*: CD ROM or tape drive) will fit between the two mounting rails of the lower drive bay. A 3.5" device will also fit, if the user provides an appropriate adapter bracket.

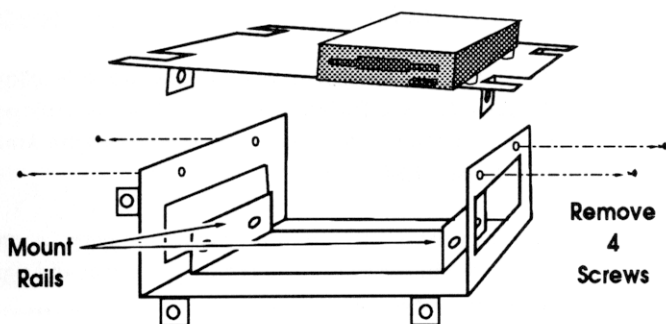

Figure A.7 – Upper tier removal showing mount rails.

NOTE: It is best to remove all expansion cards from your system before working around the lower drive bay. Mounting screws must be reached from an angle perpendicular to the rails and this is only possible when there are no printed circuit boards in the way.

- 6) Slide the 5.25" drive in between the pair of mounting rails. Orient the drive so that its 50-pin connector points toward the back of the computer. Locate the holes on the sides of the drives with the mounting slots on the rails and thread in four screws. *Do not tighten them just yet.*

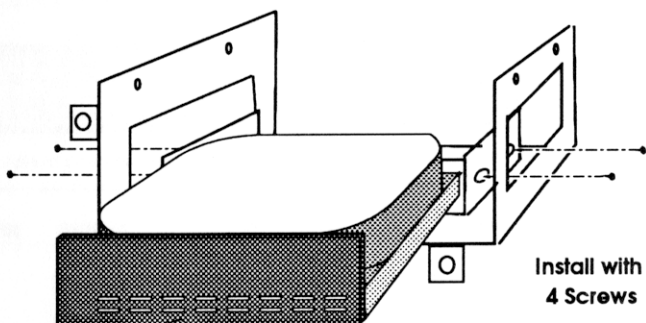

Figure A.8 – Installing drive in lower bay.



NOTE: The rails are drilled with lengthened slots, allowing the drive to be adjusted forward or back. This allows the drive to mate flush with the front panel when the Amiga's cover is installed.

- 7) Test the drive's final position by temporarily replacing the cover. When the fit is flush, remove the cover and tighten the mounting screws.

When all drives have been properly installed, reattach the Drive Stage upper tier to the lower part.

Piggy Back Drive

GVP makes available an optional bracket for mounting a low-profile 3.5" drive directly onto its line of G-Force and Combo accelerators. This bracket offers a *"no-slots-lost"* solution to the problem of a severely overcrowded machine. If you choose to purchase a Piggy Back mounting bracket, specific procedures for its installation will appear in the manual accompanying that product.



SCSI CONNECTOR PIN ASSIGNMENTS

External SCSI Connector (DB-25 Female)

Accepts standard shielded DB-25-50-pin Centronics-type SCSI cables.

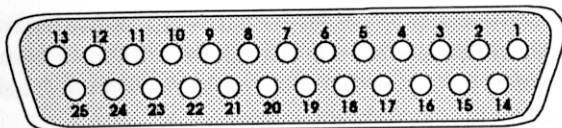

PIN	SIGNAL	PIN	SIGNAL	PIN	SIGNAL
1	REQ	9	GND	18	GND
2	MSG	10	DB(3)	19	SEL
3	I/O	11	DB(5)	20	DB(P)
4	RST	12	DB(6)	21	DB(1)
5	ACK	13	DB(7)	22	DB(2)
6	BSY	14	GND	23	DB(4)
7	GND	15	C/D	24	GND
8	DB(0)	16	GND	25	not used
		17	ATN		

NOTE: The pinout of the A2000 G-Force '040's 26 pin external SCSI header is identical to the above table. Pin 26 is not used.

Internal SCSI Connector (50-pin Header)

Accepts standard SCSI ribbon cables.

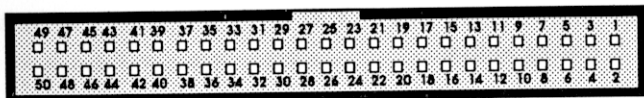

All odd pins, except pin 25, are Ground (GND). Pin 25 is not used.

PIN	SIGNAL	PIN	SIGNAL	PIN	SIGNAL
2	DB(0)	18	DB(P)	36	BSY
4	DB(1)	20	GND	38	ACK
6	DB(2)	22	GND	40	RST
8	DB(3)	24	GND	42	MSG
10	DB(4)	26	not used	44	SEL
12	DB(5)	28	GND	46	C/D
14	DB(6)	30	GND	48	REQ
16	DB(7)	32	ATN	50	I/O
		34	NC		



APPENDIX B.

TECHNICAL SUPPORT

GVP provides technical support for its hardware and software products through its network of authorized dealers. In most cases, your dealer may offer the fastest and most convenient solution when repair or replacement of equipment is necessary.

GVP also maintains a telephone Technical Support line, Monday Wednesday, Thursday and Friday, from 9:15 a.m. to 6:00 p.m. Eastern Time in the United States at (215) 354-9495. On Tuesdays, the Tech Support line opens at 10:30 a.m. Wherever possible, callers should determine that the problem they are reporting is repeatable (*i.e.: it happens more than once*), and be able to describe in detail the particular symptoms and system configuration in use.

CAUTION: Because the A2000 G-Force '040 contains delicate components that are subject to damage from shock or short circuits, use care when attempting to repeat a failed operation. Under no circumstance should a machine be powered up if it has shown evidence of electrical short circuiting. Doing so can cause irreparable damage to the G-Force board, your Amiga, or both.

GVP can also be reached via FAX, at (215) 337-9922 or by post at our U.S. mailing address:

Great Valley Products, Inc.
600 Clark Ave.
King of Prussia, PA 19406



APPENDIX C.

PROBLEM REPORTING FORM

When calling GVP Technical Support, please take the time to complete this form. Telephone support personnel will be better able to assist you if you can provide this detailed information. Users may, alternately, FAX a copy of this form to GVP at **(215) 337-9922**.

Name: _____

Date: _____

Address: _____

City: _____ State: _____

Country: _____ Postal Code: _____

Telephone Number: _____

Product: _____

Serial Number: _____

Revision: _____

Describe the problem in terms of symptoms and the conditions under which it occurs: _____



Machine Configuration

Amiga Model: _____

Motherboard Revision: _____

Kickstart (ROM) Version: _____

Workbench Version: _____

Chip Set Version: _____

Amiga CPU installed: _____

Amiga clock speed: _____

Note any and all expansion products installed (*including competitors' products*):

CPU Slot: _____

Expansion Slot #1: _____

Expansion Slot #2: _____

Expansion Slot #3: _____

Expansion Slot #4: _____

Expansion Slot #5: _____

Video Slot: _____

PC Slot #1: _____

PC Slot #2: _____

PC Slot #3: _____

PC Slot #4: _____

INDEX

26-pin Header.....	63	Bits per character.....	44
32-bit bus connectors.....	50	bits per second.....	42
32-bit pure.....	12	Bits/Character.....	44
50-pin Header.....	63	Bits/Second.....	42
68000.....	1, 49	BOOT68000.....	33
68030.....	52	bps.....	42
68040.....	1, 49	Bridgeboard.....	50
Features.....	51	Burst Mode.....	2, 13
<i>68040.library</i>	52	bus.....	49
68882.....	52		

A

Adding RAM.....	13
Amiga parallel setting.....	40
Amiga serial setting.....	39
AmigaDOS Manual.....	46
anti-static.....	7
asynchronous.....	50
AT Bridgeboard.....	50
Auto-Config memory.....	11, 50
AUX setting.....	39
Auxiliary configuration setting.....	39

B

Backward Compatibility.....	54
Baud Rate.....	42
baud.....	42
BBS Systems.....	37
Bernoulli.....	34

C

caches.....	51, 53
Cancel.....	40
Centronics connector.....	63
CHIP RAM.....	50
Clear To Send.....	43
Clock Speed.....	49
Configuration.....	6
Cooling Fan.....	26
Copyback option.....	47
CPU command.....	46
CPU CACHE option.....	47
CPU NOCACHE option.....	47
CTS.....	43
CUSTOM.....	42

D

daisy chain.....	56
data bits.....	44
data words.....	49



DCOFF.....	36
DCON.....	36, 37
Default Parallel Port.....	40
Default Serial Port.....	39
<i>Devs</i> : directory.....	38
Direct Memory Access (DMA).....	51
disconnect.....	34
Disconnect/Reconnect.....	36
DMA Peripheral and RAM Controller.....	2
DPRC.....	2
DTAK pullup.....	9

E

Edit Menu.....	45
Last Saved.....	46
Reset to defaults.....	45
Restore.....	46
Even Parity.....	43
Expansion bay support rod..	24
Extended memory.....	50
External SCSI bus locations.....	19
Connector.....	18, 63
Port.....	18

F

FaaastPrep.....	2
FaaastROM.....	2
Factory Dafault.....	6
FastPrep 2.0.....	32
FASTROM option.....	33, 46

FAX number.....	64, 65
Floating Point Math.....	52
Floating Point Unit (FPU).....	52

G

G-Force block diagram.....	51
G-Force Board Operation.....	53
Getting Started.....	3
GVP SIMM-32.....	13
<i>GVP.Install</i> disk.....	32
GVPCPUctrl.....	1, 32, 33
BOOT68000.....	33
FASTROM.....	33
MoveSSP.....	33
NOFASTROM.....	33
NoMoveSSP.....	33
GVPIInfo utility.....	47
Boards.....	48
Chips.....	48
Drives.....	48
Memory.....	48
Speed option.....	48
GVPIOControl.....	38
gvpparallel.device.....	41
GVPPar0:.....	38, 41
GVPPSCSICrl.....	34
-m argument.....	34
-m argument.....	35
-r argument.....	35
-s argument.....	35
GVPSer0:.....	38

GVPSerial utility.....	41		
Cancel.....	46		
Menus.....	45		
Save.....	46		
Unit Number.....	44		
Use.....	46		
gvpserial.device.....	41		
H			
handler.....	38		
Handshaking.....	43		
CTS/RTS.....	43		
None.....	43		
XON/XOFF.....	43		
hard disk preparation.....	32		
Hard Drive Installation.....	55		
Hardware Installation.....	22		
I			
Input Buffer Size.....	42		
Input/Output ports.....	37		
Install040 program.....	29, 30		
Installer.....	30		
Internal SCSI bus			
connector.....	18, 63		
location.....	19		
Introduction.....	1		
IOExtender parallel setting.....	40		
IOExtender serial setting.....	39		
J			
Jumpers.....	7		
locations.....	8		
pin numbering.....	7		
pins.....	7		
polarity.....	7		
shorting block.....	7		
Factory Assignments.....	10		
Three-pin Assignments.....	11		
User Assignments.....	9		
L			
L: directory.....	38		
logical devices.....	41		
M			
Mark Parity.....	44		
MAXIMUM.....	42		
Memory.....	11		
Addressing.....	50		
Memory Management			
Unit (MMU).....	52		
MFLOPS.....	1		
MIDI.....	39, 42		
MIPS.....	1		
Miscellaneous Menu.....	42, 46		
Set Custom Baud Rate.....	46		
<i>More</i> text reader.....	29		
mount.....	35		
Mounting a 3.5" drive.....	59		
Mounting a 5.25" drive.....	60		
MoveSSP.....	33		

N

NOFASTROM.....	33
NoMoveSSP.....	33

O

Odd Parity.....	44
-----------------	----

P

Parallel Port.....	17, 53
jumper setting.....	17
Parallel Default Port.....	40
Amiga setting.....	40
IOExtender setting.....	40
Unit Number setting.....	40
parallel.device.....	38
Parity.....	43
Even.....	43
Mark.....	44
None.....	43
Odd.....	44
Space.....	44
phase-error.....	36
physical devices.....	41
Piggy Back hard drive.....	62
pin one.....	25
Port Configuration setting.....	39
Port Options.....	17
Power Up Test.....	28
print spoolers.....	37
Problem Reporting Form.....	65
processor slot location.....	23

Project Menu.....	45
Open.....	45
Quit.....	45
Save As... ..	45

R

Read Only Memory.....	52
ReadMe file.....	29, 48
registers.....	49
Relocating System ROM.....	52
Request To Send.....	43
rescan.....	35
resistor packs.....	56
Ribbon cable.....	63
Ribbon cable and bracket... ..	20
Ribbon cable and connector.....	19
Ricoh.....	34
Rigid Disk Block.....	36
RS-232.....	39
RTS.....	43

S

Save.....	40
SCSI.....	18
Bus connections... ..	25, 57
Bus termination.....	57
connector Pin Assignments.....	63
Controller.....	51
hard drive cabling and mounting.....	20
Terminating resistors... ..	55
Unit ID Numbers.....	55

Serial Port.....	53
Amiga setting.....	39
AUX.....	39
Auxiliary configuration setting.....	39
Default Port.....	39
IOExtender setting.....	39
MIDI.....	39
Configuration setting...39	
RS-232.....	39
Unit Number setting.....	39
serial.device.....	38
Set Custom Baud Rate.....	42
Single Inline Memory Modules (SIMMs)	11
installation.....	14
Installation procedure..	15
sockets.....	14
Small Computer Standard Interface (SCSI).....	18
Software Installation.....	29
Software Reference.....	32
Space Parity.....	44
sticky mount.....	35
Stop bits.....	44
SyQuest.....	34, 35

T

Technical Support.....	64, 65
telecommunications software.....	37
Terminating Resistors.....	55
Theory of Operation.....	49
Tooltypes.....	45

U

Unit Numbers parallel setting.....	40
SCSI Unit ID.....	55
serial setting.....	39
Use.....	40
Using GVPSCSIctrl.....	37

W

Wangtek tape drive.....	34
wrist strap.....	7

X

XOFF.....	43
XON.....	43
XT Bridgeboard.....	50



GREAT VALLEY PRODUCTS
600 CLARK AVENUE
KING OF PRUSSIA, PA 19406
U.S.A.
PHONE 215 • 337 • 8770
FAX 215 • 337 • 9922

A2000 G-Force 040 Combo is a trademark of Great Valley Products, Inc.
Amiga is a registered trademark of Commodore-Amiga, Inc.

© 1992 Great Valley Products, Inc.
All rights reserved.